

PS536GS
Gas
Domestic, Std. Export & CE
ENGLISH

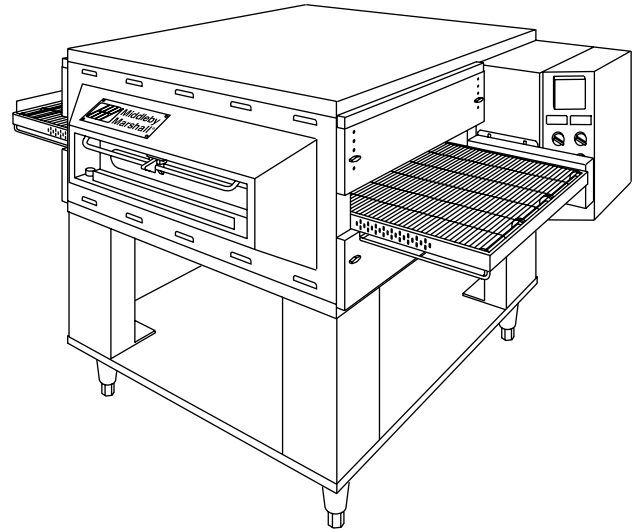

P/N 50236
November 18, 2008 Rev.E
Price \$30.00

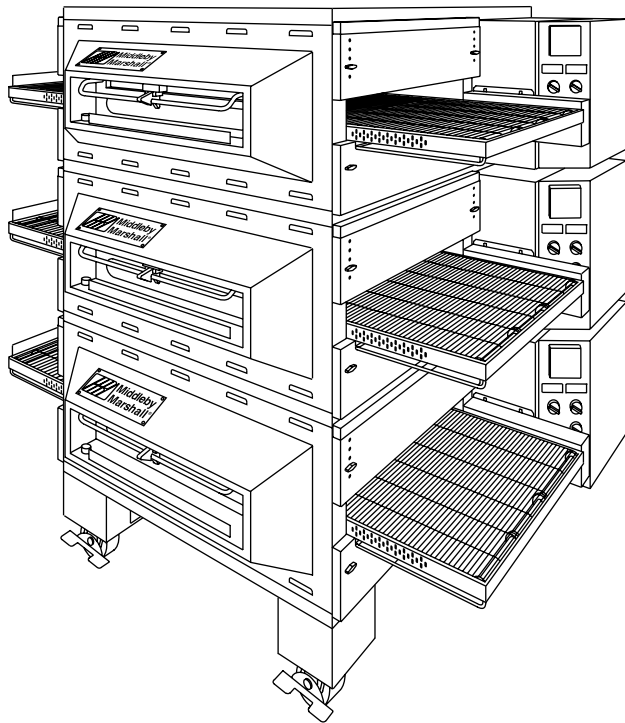

PS536GS Gas Ovens

Models:

- PS536GS Gas

Combinations:

- Single Oven
- Double Oven (Two-Stack)
- Triple Oven (Three-Stack)

OWNER'S OPERATING, INSTALLATION, AND PARTS MANUAL

for domestic, standard export and CE export ovens

© 2003 Middleby Marshall, Inc.

 **Middleby Marshall**® is a registered trademark of Middleby Marshall, Inc. All rights reserved.

Middleby Cooking Systems Group • 1400 Toastmaster Drive • Elgin, IL 60120 • (847)741-3300 • FAX (847)741-4406



NOTICE:

This Owner's Operating and Installation Manual should be given to the user. The operator of the oven should be familiar with the functions and operation of the oven.

This manual must be kept in a prominent, easily reachable location near the oven.

Ovens are shipped from the factory configured for use with natural gas. If permitted by local, national and international codes, at the time of installation the oven may be converted to propane gas operation. This conversion requires the use of a Gas Conversion Kit that is supplied with the oven. For CE-approved ovens, the conversion is described in the *Installation* section of this Manual. For domestic and standard export ovens, instructions are included in the Gas Conversion Kit.

It is suggested to obtain a service contract with a Middleby Marshall Authorized Service Agent.

WARNING

POST, IN A PROMINENT LOCATION, THE EMERGENCY TELEPHONE NUMBER OF YOUR LOCAL GAS SUPPLIER AND INSTRUCTIONS TO BE FOLLOWED IN THE EVENT YOU SMELL GAS.

Instructions to be followed in the event the user smells gas shall be obtained by consulting the local gas supplier. If the smell of gas is detected, immediately call the emergency phone number of your local Gas Company. They will have personnel and provisions available to correct the problem.

FOR YOUR SAFETY

Do not store or use gasoline or other flammable vapors or liquids in the vicinity of this or any other appliance.

WARNING:

Improper installation, adjustment, alteration, service or maintenance can cause property damage, injury or death. Read the installation, operating and maintenance instructions thoroughly before installing or servicing this equipment.

IMPORTANT

An electrical wiring diagram for the oven is located inside the machinery compartment.

IMPORTANT

It is the customer's responsibility to report any concealed or non-concealed damage to the freight company. Retain all shipping materials until it is certain that the equipment has not suffered concealed shipping damage.

NOTICE: CONTACT YOUR MIDDLEBY MARSHALL AUTHORIZED SERVICE AGENT TO PERFORM MAINTENANCE AND REPAIRS. AN AUTHORIZED SERVICE AGENCY DIRECTORY IS SUPPLIED WITH YOUR OVEN.

NOTICE: Using any parts other than genuine Middleby Marshall factory manufactured parts relieves the manufacturer of all warranty and liability.

NOTICE: Middleby Marshall (Manufacturer) reserves the right to change specifications at any time.

NOTICE: The equipment warranty is not valid unless the oven is installed, started and demonstrated under the supervision of a factory certified installer.

Retain This Manual For Future Reference

Middleby Cooking Systems Group • 1400 Toastmaster Drive • Elgin, IL 60120 • USA • (847)741-3300 • FAX (847)741-4406
24-Hour Service Hotline: 1-(800)-238-8444 • Middleby Customer Care Center: 1-(800)-630-6559

www.middleby.com

TABLE OF CONTENTS

| | <i>page</i> | | <i>page</i> |
|--|-------------|--|-------------|
| SECTION 1 - DESCRIPTION | 4 | B. Connection | 13 |
| I. OVEN USES | 4 | V. GAS SUPPLY | 14 |
| II. OVEN COMPONENTS | 4 | A. Gas Utility Rough-In Recommendations | 14 |
| A. Window | 4 | B. Connection | 14 |
| B. Conveyor End Stop | 4 | C. Gas Conversion | 14 |
| C. Eyebrows | 4 | D. PS536 Propane Conversion | 14 |
| D. End Plugs | 4 | E. Adjusting the Maximum Pressure Setting | 14 |
| E. Control Panel | 4 | F. Adjusting the Minimum Pressure Setting | 15 |
| F. Machinery Compartment and Control Compartment Doors | 4 | G. Checkout | 15 |
| G. Serial Plate | 4 | H. Maintenance | 15 |
| H. Conveyor Drive Motor | 4 | SECTION 3 - OPERATION | 17 |
| I. Crumb Pans | 4 | I. LOCATION AND DESCRIPTION OF CONTROLS . | 17 |
| J. Conveyor | 4 | A. BLOWER (☼) Switch | 17 |
| K. Gas Burner | 4 | B. HEAT (☼) Switch | 17 |
| L. Blowers | 4 | C. CONVEYOR (☼) Switch | 17 |
| M. Air Fingers | 4 | D. Conveyor Speed Controller | 17 |
| III. OVEN SPECIFICATIONS | 4 | E. Digital Temperature Controller | 17 |
| A. Dimensions | 4 | F. Machinery and Control Compartment Safety Switches | 17 |
| B. General Specifications | 4 | II. NORMAL OPERATION, STEP-BY-STEP | 18 |
| C. Electrical Specifications for Gas Ovens | 5 | A. Daily Startup Procedure | 18 |
| D. Gas Orifice and Pressure Specifications - Domestic and Standard Export Ovens | 5 | B. Daily Shutdown Procedure | 18 |
| E. Gas Orifice and Pressure Specifications - CE Ovens | 5 | III. QUICK REFERENCE: DIGITAL TEMPERATURE CONTROLLER | 19 |
| SECTION 2 - INSTALLATION | 6 | SECTION 4 - MAINTENANCE | 20 |
| I. INSTALLATION KIT | 7 | I. MAINTENANCE - DAILY | 20 |
| II. VENTILATION SYSTEM | 8 | II. MAINTENANCE - MONTHLY | 21 |
| A. Requirements | 8 | III. MAINTENANCE - EVERY 3 MONTHS | 21 |
| B. Recommendations | 8 | IV. MAINTENANCE - EVERY 6 MONTHS | 23 |
| C. Other Ventilation Concerns | 8 | SECTION 5 - PARTS LIST | 24 |
| III. ASSEMBLY | 9 | SECTION 5 - ELECTRICAL WIRING DIAGRAMS | 25 |
| A. Top Panel and Base Pad Assembly | 9 | I. WIRING DIAGRAM, PS536GS GAS OVEN (DOMESTIC & STD. EXPORT VERSION), 208/240V, 50/60 Hz, 1 Ph | 25 |
| B. Stacking | 10 | | |
| C. Restraint Cable Installation | 10 | | |
| D. Conveyor Installation | 11 | | |
| E. Final Assembly | 12 | | |
| IV. ELECTRICAL SUPPLY | 13 | | |
| A. Additional Information - Gas Ovens | 13 | | |

SECTION 1 - DESCRIPTION

I. OVEN USES

PS536GS ovens can be used to bake and/or cook a wide variety of food products, such as pizza, pizza-type products, cookies, sandwiches and others.

II. OVEN COMPONENTS - see Figure 1-1.

- A. Window:** Allows the user to see and access food products inside the baking chamber.
- B. Conveyor End Stop :** Prevents food products from falling off the end of the moving conveyor.
- C. Eyebrows:** Can be adjusted to various heights to prevent heat loss into the environment.
- D. End Plugs:** Allow access to the oven's interior.
- E. Control Panel:** Location of the operating controls for the oven. Refer to Section 3, Operation, for details.
- F. Machinery Compartment and Control Compartment Doors:** Allow access to the oven's interior components. One door is located at each end of the oven. No user-servicable parts are located inside the machinery compartment or control compartment.
- G. Serial Plate:** Provides specifications for the oven that affect installation and operation. Refer to Section 2, Installation, for details.
- H. Conveyor Drive Motor:** Moves the conveyor.
- I. Crumb Pans:** Catch crumbs and other material that drop through the conveyor belt. One crumb pan is located underneath each end of the conveyor.

- J. Conveyor:** Moves the food product through the oven.
Not Shown:
- K. Gas Burner:** Heats air, which is then projected to the air fingers by the blowers.
- L. Blowers:** Fans that project hot air from the gas burner to the air fingers.
- M. Air Fingers:** Project streams of hot air onto the food product.

Fig. 1-1 - Oven Components

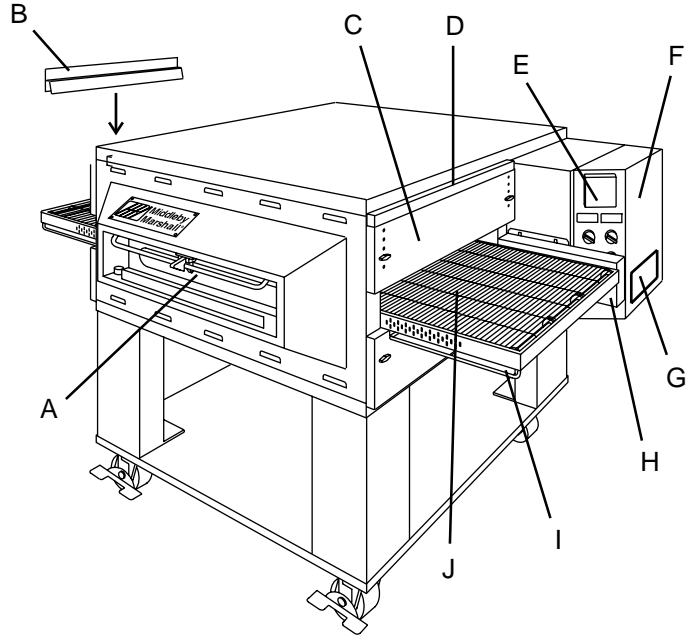

III. OVEN SPECIFICATIONS

Table 1-1: Dimensions

| | | |
|--|--|--|
| Overall Height: | single oven with 17-1/2" (446mm) legs | 43-1/2" (1105mm) |
| | double oven with standard 17-1/2" (446mm) legs | 63" (1600mm) |
| | double oven with optional 20-1/2" (521mm) legs | 66" (1676mm) |
| | double oven with optional 25-1/2" (648mm) legs | 71" (1803mm) |
| | triple oven with 6" (152mm) legs | 71" (1803mm) |
| Overall Depth: | | 46" (1168mm) |
| Overall Length: | with standard 60"/1524mm conveyor | 61" (1549mm) |
| | with optional 56"/1422mm conveyor | 57" (1447mm) |
| | with optional 76"/1930mm conveyor | 77" (1956mm) |
| Baking Chamber Length | | 36" (914mm) |
| Conveyor Width: | Single Belt | 20" (508mm) |
| | Split Belt | 2 x 9-1/2" (241mm) |
| Conveyor Length | | 56" (1422mm) or 60" (1524mm) or 76" (1930mm) |
| Recommended Minimum Clearances: | | |
| | Rear of oven to wall | 3" (76mm) |
| | Control end of conveyor to wall | 1" (25.4mm) |
| | Non-control end of oven to wall | 1" (25.4mm) |

Table 1-2: General specifications (per oven cavity)

| | | |
|--------------------------------------|-------------------|--|
| Weight | | 400 lbs. (182kg) |
| Rated Heat Input: | Natural gas ovens | 70,000 BTU (17,638 kcal, 20.51 kW/hr.) |
| | Propane ovens | 70,000 BTU (17,638 kcal, 20.51 kW/hr.) |
| Maximum Operating Temperature | | 550°F (288°C) |
| Warmup Time | | 25 minutes |

Table 1-3: Electrical specifications for gas ovens (per oven cavity)

| Main Blower Voltage | Control Circuit Voltage | Phase | Freq. | Current Draw | Poles | Wires |
|----------------------------|---|--------------|--------------|---------------------|--------------|-----------------------|
| 208/240V | 120V conv. speed control & drive motor; all others as per line (208/240V) | 1 Ph | 50/60 Hz | 6A * | 2 Pole | 3 Wire (2 hot, 1 gnd) |

* The current draw shown above is an average value for normal operation. The initial amperage draw on oven startup may exceed the listed value.

Table 1-4: Gas orifice and pressure specifications (per oven cavity) - Domestic and standard export ovens

| Gas Type | Main Orifice I.D. | Supply (Inlet) Pressure | Orifice (Manifold) Pressure |
|-----------------|-------------------------------|--------------------------------|------------------------------------|
| Natural | 0.0935" (2.3749mm, #42 drill) | 6-12" W.C. (14.9-29.9mbar) * | 4.0" W.C. (9.93mbar) |
| Propane | 0.081" (2.0574mm, #46 drill) | 11-14" W.C. (27.4-34.9mbar) * | 10.5" W.C. (26.15mbar) |

* The gas supply pressures and orifice sizes shown are for ovens installed in North America. The required gas supply pressures and orifice sizes of ovens installed in other locations are dependent on the local gas type and on all applicable local codes.

Table 1-5: Gas orifice and pressure specifications (per oven cavity) - CE ovens

| Gas Type | Main Orifice dia. | Supply (Inlet) Pressure | | | | | | Orifice (Manifold) Pressure | Rated Heat Input |
|-----------------|--------------------------|---|------------------------------|------------------------------|----------------------------------|---|--|------------------------------------|-------------------------|
| | | <i>IT,PT,ES,SE, UK,CH,IT,AT, DK,FI I_{2H}</i> | <i>NL I_{2L}</i> | <i>DE I_{2E}</i> | <i>BE,FR I_{2E+}</i> | <i>SE,CH,AT,DK, FI,DE,NL I_{3B/P}</i> | <i>BE,IE,IT,PT, ES,UK I₃₊</i> | | |
| G20 | 2.3749 mm | 20 mbar | -- | 20 mbar | 20 mbar | -- | -- | 11.21 mbar | 22.36 kW-hr. |
| G25 | 2.3749 mm | -- | 25 mbar | -- | -- | -- | -- | 16.19 mbar | 22.36 kW-hr. |
| G30 | 1.3970 mm | -- | -- | -- | -- | 29 or 50 mbar | 28-30, 37 or 50 mbar | 26.2 mbar | 22.59 kW-hr. |

IMPORTANT

Additional electrical information is provided on the oven's serial plate, and on the wiring diagram inside the machinery compartment.

SECTION 2 - INSTALLATION

WARNING - For gas ovens, after any conversions, readjustments, or service work on the oven:

- Perform a gas leak test.
- Test for correct air supply.
- Test for proper combustion and gas supply.
- Check that the ventilation system is in operation.

WARNING

Keep the appliance area free and clear of combustibles.

WARNING

The oven must be installed on an even (level) non-flammable flooring and any adjacent walls must be non-flammable. Recommended minimum clearances are specified in the *Description* section of this Manual.

WARNING

Do not obstruct the flow of combustion and ventilation air to and from your oven. There must be no obstructions around or underneath the oven. Constructional changes to the area where the oven is installed shall not affect the air supply to the oven.

CAUTION

For additional installation information, contact your local Authorized Service Agent.

NOTE

There must be adequate clearance between the oven and combustible construction. Clearance must also be provided for servicing and for proper operation.

NOTE

An electrical wiring diagram for the oven is located inside the machinery compartment.

NOTE

All aspects of the oven installation, including placement, utility connections, and ventilation requirements, must conform with any applicable local, national, or international codes. These codes supersede the requirements and guidelines provided in this manual.

NOTE

In the USA, the oven installation must conform with local codes. In the absence of local codes, gas oven installations must conform with the National Fuel Gas Code, ANSI Z223.1. Installed ovens must be electrically grounded in accordance with local codes, or in the absence of local codes, with the National Electrical Code (NEC), or ANSI/NFPA70.

NOTE

In Canada, the oven installation must conform with local codes. In the absence of local codes, gas oven installations must conform with the Natural Gas Installation Code, CAN/CGA-B149.1, or the Propane Gas Installation Code, CAN/CGA-B149.2, as applicable. Installed ovens must be electrically grounded in accordance with local codes, or in the absence of local codes, with the Canadian Electrical Code CSA C22.2.

NOTE

In Australia, the oven installation must conform with any requirements of the appropriate statutory authority. Gas oven installations must conform with AGA Codes AG311 and AG601.

NOTE

In CE countries, all aspects of the gas supply connection must comply with current IEC/CEE requirements and with all applicable local, national, and international codes. In addition, four casters are provided to allow the oven to be more easily moved to the installation location. These casters are intended to simplify pre-installation movement only, and are NOT suitable for use as part of a CE oven installation. During the installation procedure, the casters MUST be removed, so that the oven can be supported by the supplied 152mm adjustable legs.

Figure 2-1 - Installation Kit

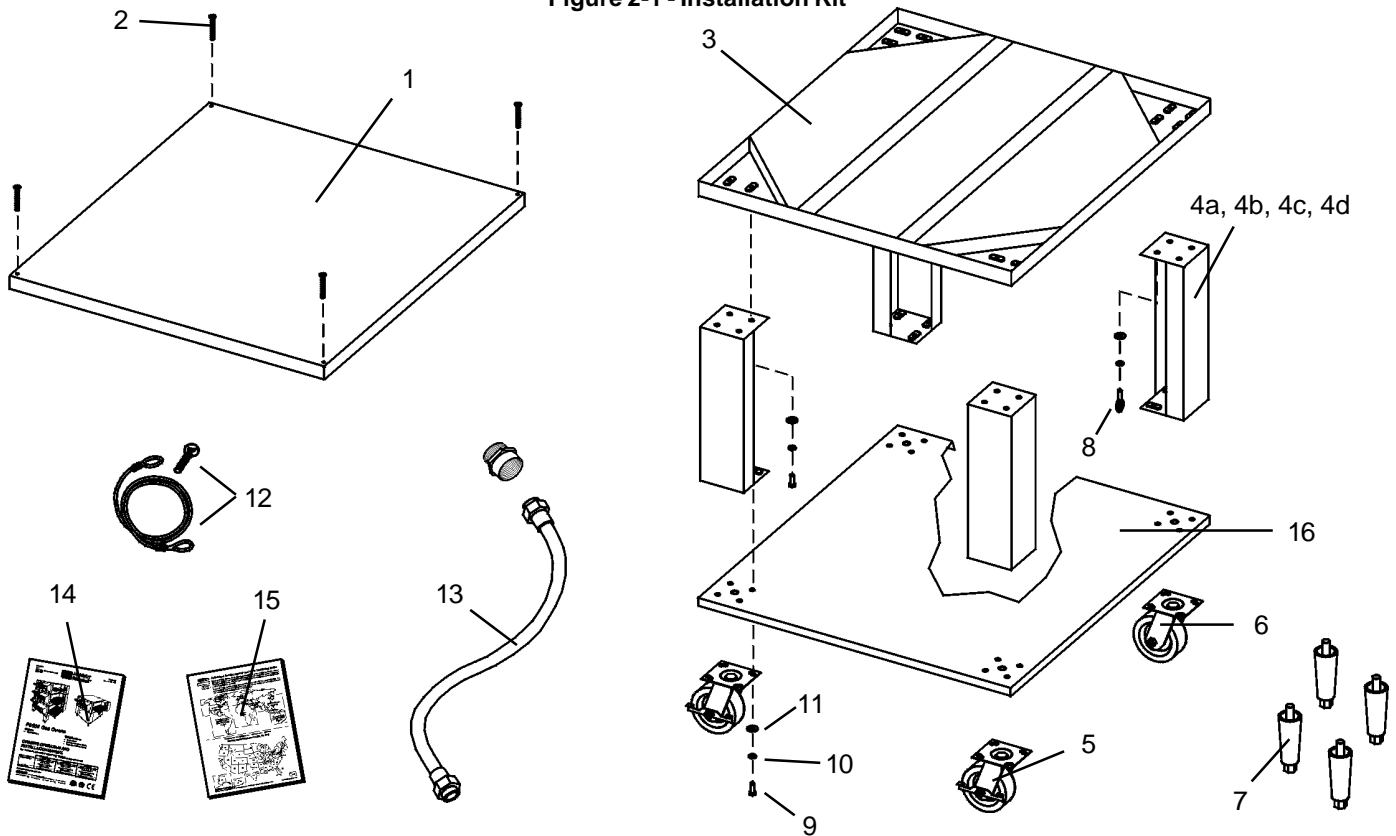

I. INSTALLATION KIT - see Figure 2-1

| Item | Qty. Single Oven | Qty. Double Oven | Qty. Triple Oven | Part No. | Inc. with domestic ovens? | Inc. with CE ovens? | Description |
|---|------------------------|------------------------|------------------------|------------|---------------------------------|---------------------------|---|
| 1 | 1 | 1 | 1 | 48605 | Yes | Yes | Top panel |
| 2 | 4 | 4 | 4 | 3A80A8801 | Yes | Yes | Screw, pan head #10 x 2" |
| 3 | 1 | 1 | 1 | 42893 | Yes | Yes | Base pad |
| 4a | 4 | 4 | -- | 42890 | Yes | Yes | 17-1/2" (445mm) leg extension, for single and double ovens |
| 4b | -- | 4 | -- | 45360 | Yes | Yes | 20-1/2" (521mm) leg extension, optional |
| 4c | -- | 4 | -- | 45329 | Yes | Yes | 25-1/2" (648mm) leg extension, optional |
| 4d | -- | -- | 4 | 44799 | Yes | Yes | 6" (152mm) leg extension, for triple ovens |
| 5 | 2 | 2 | 2 | 22290-0009 | Yes | No | Caster, with flat plate and brake |
| 6 | A/R | A/R | A/R | 22290-0010 | Yes | Yes | Caster, with flat plate (no brake) |
| NOTE: Domestic and standard export ovens include 2 braking casters (item 5) and 2 non-braking casters (Item 6). CE-approved ovens include 4 non-braking casters (Item 6) SOLELY for the purpose of moving the oven to the installation location. Casters are NOT suitable for use as part of CE oven installations. Refer to the notice on the preceding page. | | | | | | | |
| 7 | 4 | 4 | 4 | 22450-0028 | No | Yes | Leg, adjustable, 6" (152mm) |
| 8 | 1 | 1 | 1 | 21392-0004 | Yes | No | Eyebolt, 3/4" |
| 9 | A/R | A/R | A/R | 220373 | Yes | Yes | Hex bolt, 3/8"-16 x 1" |
| NOTE: CE-approved ovens include 32 hex bolts. Domestic and standard export ovens include 31 hex bolts and one eyebolt (item 8) that acts as an anchor for the restraint cable (Item 12). CE ovens are mounted on legs (Item 7) and do not use a restraint cable. | | | | | | | |
| 10 | 32 | 32 | 32 | 21416-0001 | Yes | Yes | Flat washer, 3/8" |
| 11 | 32 | 32 | 32 | 21422-0001 | Yes | Yes | Lockwasher, 3/8" |
| 12 | 1 | 1 | 1 | 22450-0228 | Yes | No | Restraint cable assembly |
| 13 | 1 | 2 | 3 | 22361-0001 | Yes | No | Gas hose, 3/4" to 1/2" Gas hose reducer included with gas hose. |
| 14 | 1 | 1 | 1 | 50236 | Yes | Yes | Owner's Operating and Installation Manual |
| 15 | 1 | 1 | 1 | 1002040 | Yes | Yes | Authorized Service Agency Listing |
| 16 | 1 | 1 | -- | 46393 | Yes | Yes | Lower shelf |

II. VENTILATION SYSTEM

IMPORTANT

Where national or local codes require the installation of fire suppression equipment or other supplementary equipment, **DO NOT** mount the equipment directly to the oven.

MOUNTING SUCH EQUIPMENT ON THE OVEN MAY:

- **VOID AGENCY CERTIFICATIONS**
- **RESTRICT SERVICE ACCESS**
- **LEAD TO INCREASED SERVICE EXPENSES FOR THE OWNER**

A. Requirements

CAUTION

Gas oven installations REQUIRE a mechanically driven ventilation system with electrical exhaust air sensing control.

A mechanically driven ventilation system is STRONGLY RECOMMENDED for electric oven installations.

PROPER VENTILATION OF THE OVEN IS THE RESPONSIBILITY OF THE OWNER.

B. Recommendations

NOTE THAT THE HOOD DIMENSIONS SHOWN IN FIGURE 2-2 ARE RECOMMENDATIONS ONLY. LOCAL, NATIONAL AND INTERNATIONAL CODES MUST BE FOLLOWED WHEN INSTALLING THE VENTILATION SYSTEM. ANY APPLICABLE CODES SUPERSEDE THE RECOMMENDATIONS SHOWN IN THIS MANUAL.

The rate of air flow exhausted through the ventilation system may vary depending on the oven configuration and hood design. Consult the hood manufacturer or ventilation engineer for these specifications.

To avoid a negative pressure condition in the kitchen area, return air must be brought back to replenish the air that was exhausted. A negative pressure in the kitchen can cause heat-related problems to the oven components as if there were no ventilation at all. The best method of supplying return air is through the heating, ventilation and air conditioning (HVAC) system. Through the HVAC system, the air can be temperature-controlled for summer and winter. Return air can also be brought in directly from outside the building, but detrimental effects can result from extreme seasonal hot and cold temperatures from the outdoors.

NOTE: Return air from the mechanically driven system must not blow at the opening of the baking chamber. Poor oven baking performance will result.

C. Other ventilation concerns

- Special locations, conditions, or problems may require the services of a ventilation engineer or specialist.
- Inadequate ventilation can inhibit oven performance.
- It is recommended that the ventilation system and duct work be checked at prevailing intervals as specified by the hood manufacturer and/or HVAC engineer or specialist.

Fig. 2-2 - Ventilation System

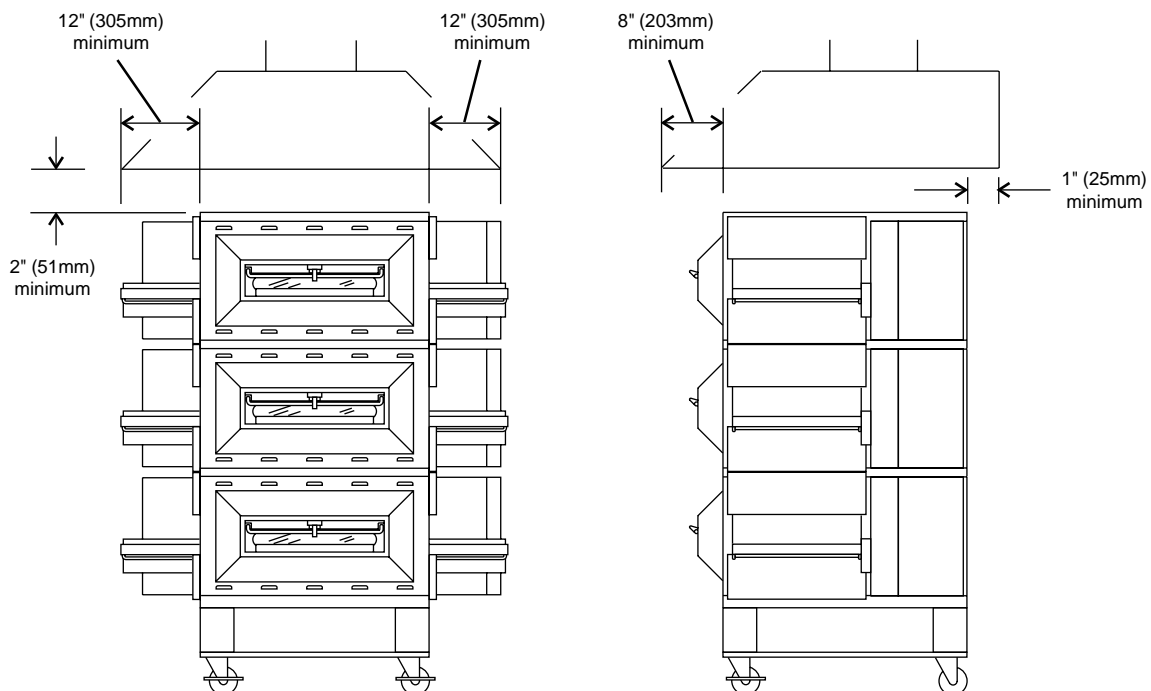

III. ASSEMBLY

A. Top Panel and Base Pad Assembly

1. Install the four leg extensions onto the base pad using the 3/8"-16x1" screws, 3/8" flat washers, and 3/8" lockwashers supplied in the Base Pad Kit. See Figure 2-3. Check that the finished sides of each leg extension face **OUTWARDS**.

For domestic and standard export ovens:

One rear leg should be attached using three 3/8"-16 x 1" screws and the 3/4" eyebolt, as shown in Figure 2-3. This eyebolt acts as the anchor point for the restraint cable assembly (see Part C, Restraint Cable Installation).

2. If your oven is equipped with the lower shelf, position it in place as shown in Figure 2-3. Check that the lip on the shelf faces **DOWN**. Seal joint between leg and shelf with NSF listed silicone.

3. *For domestic and standard export ovens:*

Install one caster onto each leg extension, as shown in Figure 2-4. Use the 3/8"-16x1" screws, 3/8" flat washers, and 3/8" lockwashers supplied in the Installation Kit. The locking casters should be installed at the **FRONT** of the oven. The non-locking casters should be installed at the **REAR** of the oven.

For CE export ovens:

The Installation Kit includes four casters AND four 152mm adjustable legs. The casters are provided to allow the oven to be more easily moved to the installation location, and are **NOT** suitable for use as part of the oven installation. Refer to the notice at the beginning of this Section.

After the oven is at the installation location, install one 152mm adjustable leg into the center hole on the bottom of each leg extension, as shown in Figure 2-4.

4. Install the lower oven cavity onto the base pad. See Fig. 2-4.
5. For single ovens **ONLY**, install the top panel using the screws included in the base pad kit, as shown in Figure 2-5. Then, skip ahead to Part C, Restraint Cable Installation.

For double or triple ovens, continue on to Part B, Stacking. Note that the top panel should **NOT** be installed for double and triple ovens until after stacking the oven cavities.

Figure 2-3 - Leg extension and casters installation

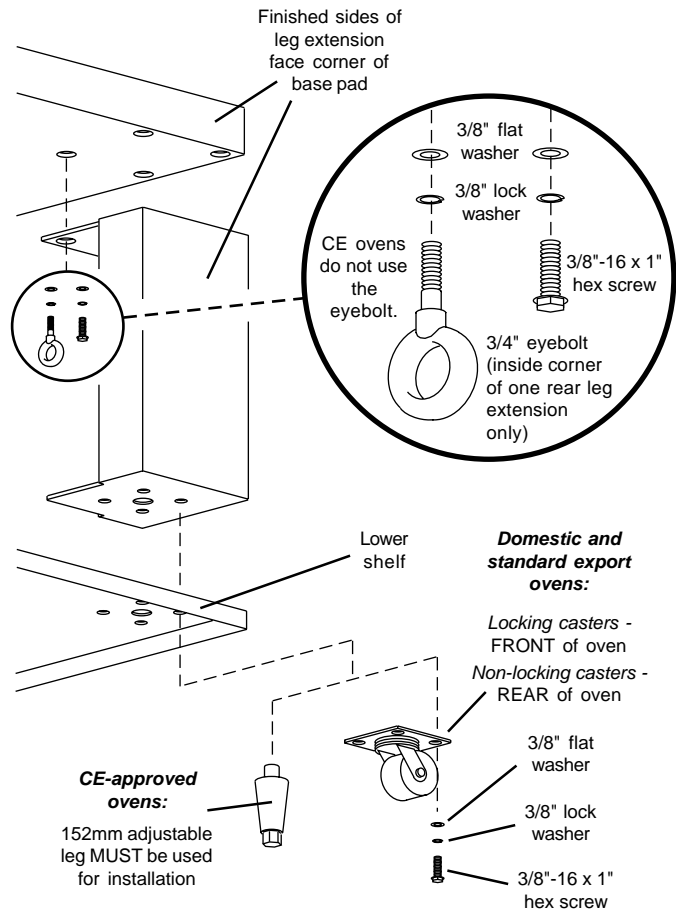

Figure 2-4 - Base pad installation

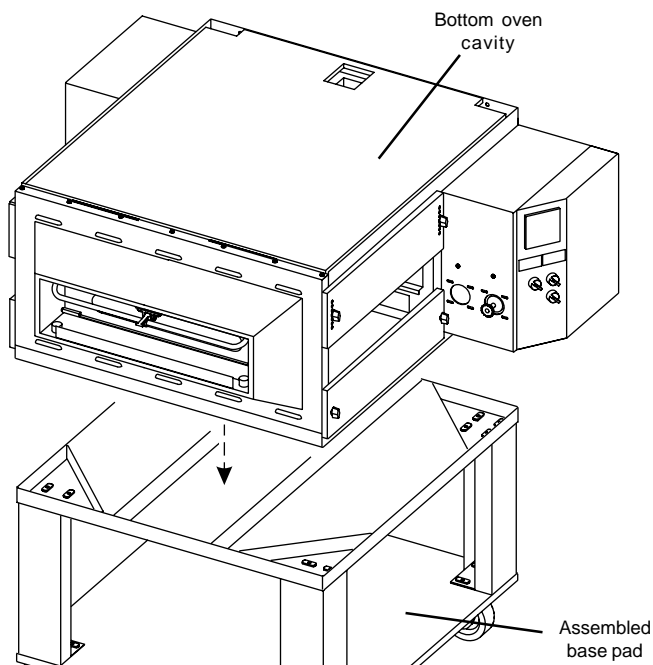
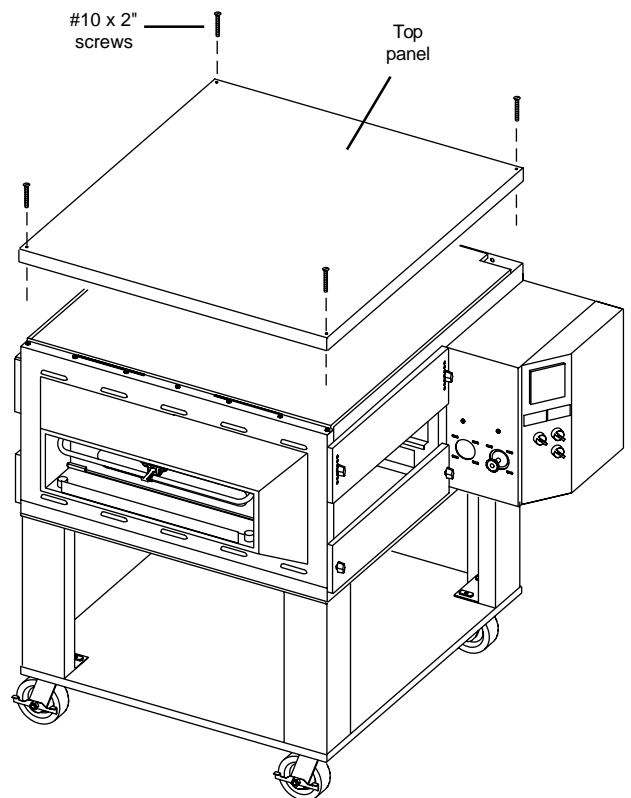

Figure 2-5 - Top panel installation

NOTE: DO NOT install top panel onto double or triple ovens until **AFTER** stacking the oven cavities. See Part B, Stacking.



B. Stacking

For single ovens, skip ahead to Part C, Restraint Cable Installation.

IMPORTANT

Middleby Marshall STRONGLY RECOMMENDS that PS536GS oven cavities be stacked using the following:

- PS500 Series Stacking Lift Kit, P/N 30580
- PS536 Stacking Hardware Kit, P/N 46494

Contact your Middleby Marshall Authorized Service Agent for complete stacking instructions.

1. Stack an oven cavity on top of the lower oven. Check the following:
 - All four sides of the lower lip (on the bottom edge of the oven cavity) overlap the top of the lower oven.
 - The oven is level.
 - The oven is firmly seated.

See Figure 2-6.

2. For triple ovens, repeat Step 1 to install the top oven cavity.
3. Install the top panel using the screws included in the base pad kit, as shown in Figure 2-7.

Figure 2-6 - Stacking

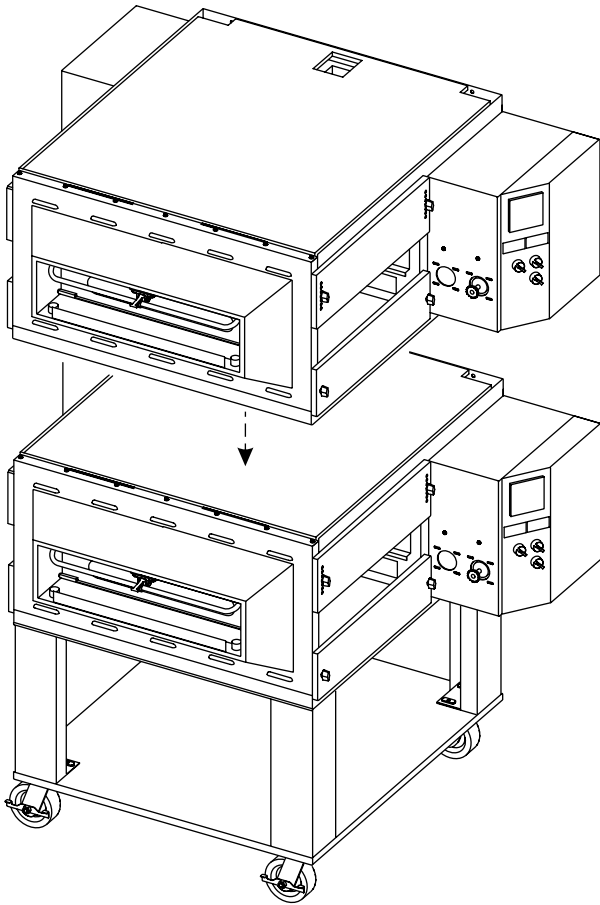
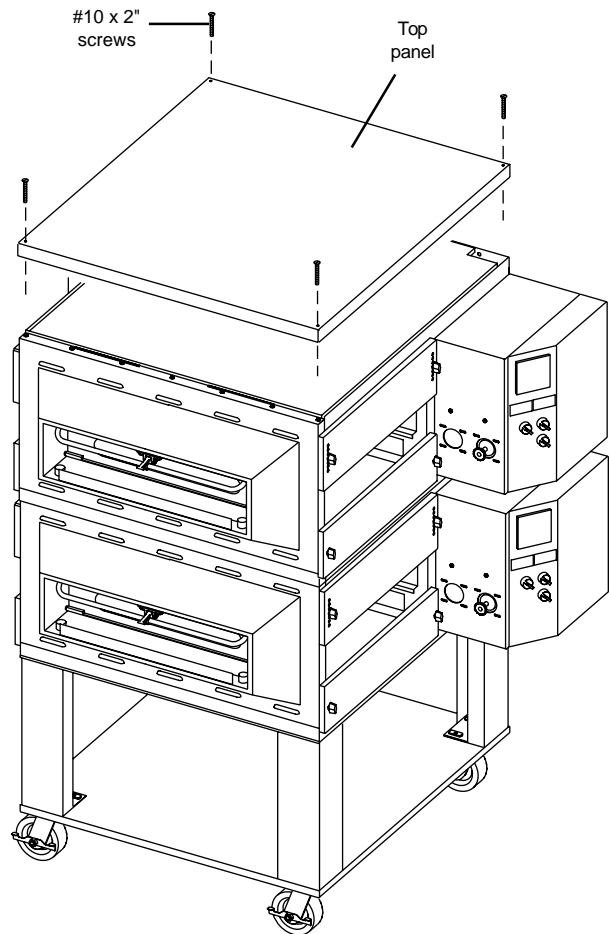

Figure 2-7 - Top panel installation



C. Restraint Cable Installation

For CE-approved ovens, skip ahead to Part D, Conveyor Installation.

For domestic and standard export ovens, continue with this Section to install the restraint cable.

Because domestic and standard export ovens are equipped with casters, a restraint cable assembly must be installed to limit the movement of the appliance without depending on the connector and the quick disconnect device or its associated piping. One end of the cable is anchored to the eyebolt on one of the rear leg extensions, while the other is anchored to the wall. See Figure 2-8.

After connecting the restraint cable, move the oven to its final location. Then, lock the two front casters.

Figure 2-8 - Installing the Restraint Cable

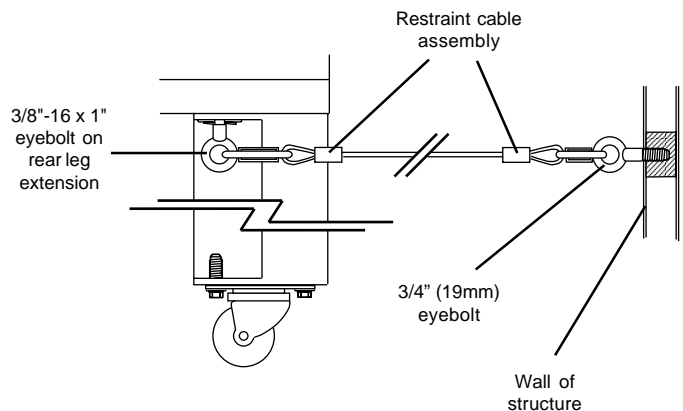

D. Conveyor Installation

1. Unfold the conveyor as shown in Figure 2-9. Then, begin to slide the conveyor into the end of the oven. The conveyor can only be installed from the end of the oven with the drive motor.
2. Continue moving the conveyor into the oven until the frame protrudes equally from each end of the oven. Check that the crumb tray supports located on the underside of the conveyor frame rest firmly against the lower end plugs, as shown in Figure 2-10.
3. When the conveyor is positioned properly, check for freedom of movement of the conveyor belt by pulling it for about 2-3 feet (0.6-1.0m) with your fingers. The drive and idler shafts must rotate smoothly, and the belt must move freely without rubbing on the inside of the oven.
4. Check the tension of the conveyor belt as shown in Figure 2-11. The belt should lift about 1" (25mm). **DO NOT OVERTIGHTEN THE CONVEYOR BELT.**

NOTE:

If necessary, the belt tension can be adjusted by turning the conveyor adjustment screws, located at the idler (non-control) end of the conveyor. See Figure 2-11.

Figure 2-9 - Conveyor installation

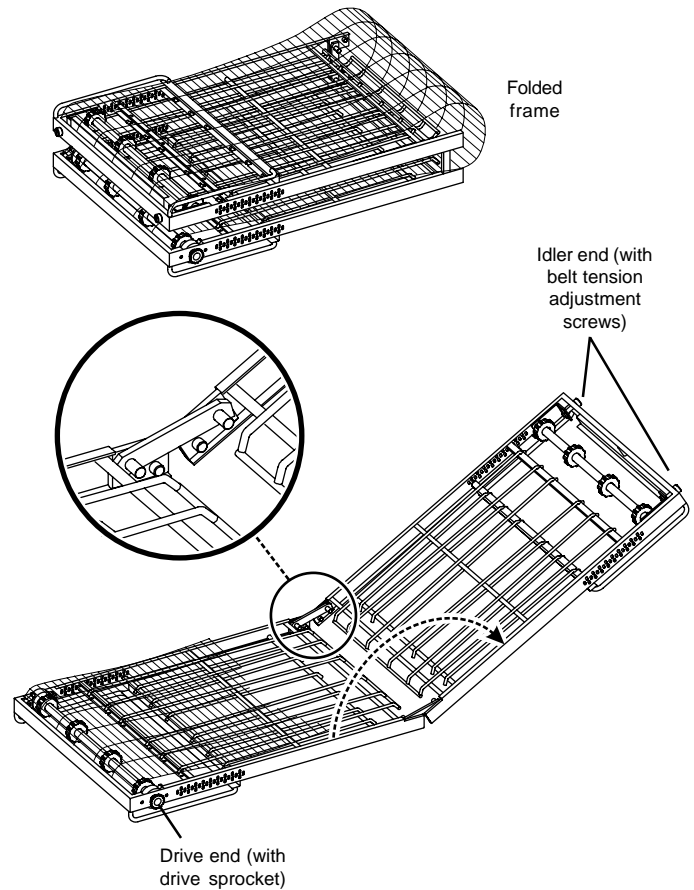

Figure 2-10 - Conveyor placement

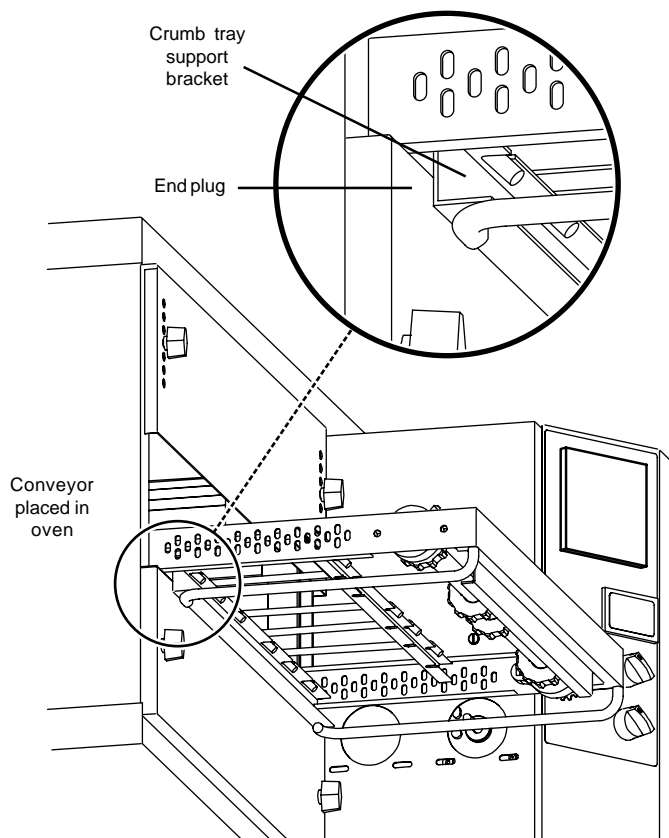
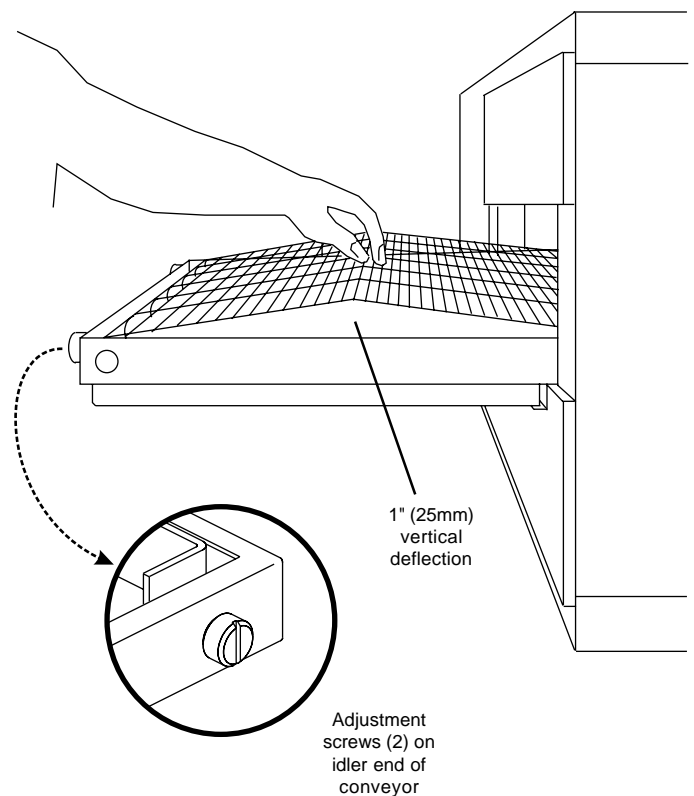

Figure 2-11 - Conveyor belt tension



SECTION 2 - INSTALLATION

5. If it is necessary to add or remove conveyor links to achieve the correct tension, OR if it is necessary to reverse the conveyor belt for correct orientation, the belt will need to be removed from the conveyor frame. If this is necessary, perform the following procedure:
 - Remove the conveyor assembly from the oven and place it flat on the floor.
 - Remove the master links using long-nose pliers. Then, roll up the belt along the length of the conveyor frame.
 - Add or remove belt links as necessary to achieve the correct belt tension.
 - Replace the belt on the conveyor frame. Check that the conveyor belt links are oriented as shown in Figure 2-12, and that the smooth side of the conveyor belt faces UP.
 - Connect the inside master links. Check that the links are oriented as shown in Figure 2-12.
 - Connect the outside master links. Note that the outside master links each have an open hook on one side. This hook aligns with the hooks along the sides of the other conveyor links. See Figure 2-12.
 - Replace the conveyor into the oven.

E Final Assembly

6. Install the drive chain between the conveyor drive sprocket and the motor sprocket. To install the chain, it will be necessary to lift the drive end of the conveyor slightly.
7. Install the conveyor chain cover as shown in Figure 2-13. Check that the chain cover does not bind on the conveyor sprocket or drive shaft.
8. Install the crumb trays as shown in Figure 2-13.
9. Press the end stop down over the edge of the conveyor frame at the exit end of the oven, as shown in Figure 2-13.

Figure 2-12 - Conveyor and master link orientation

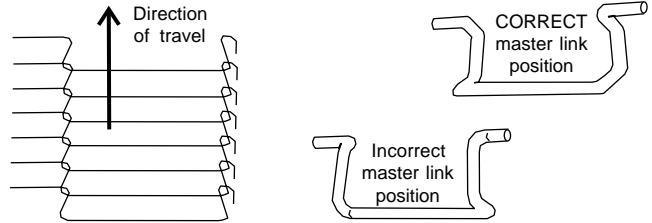
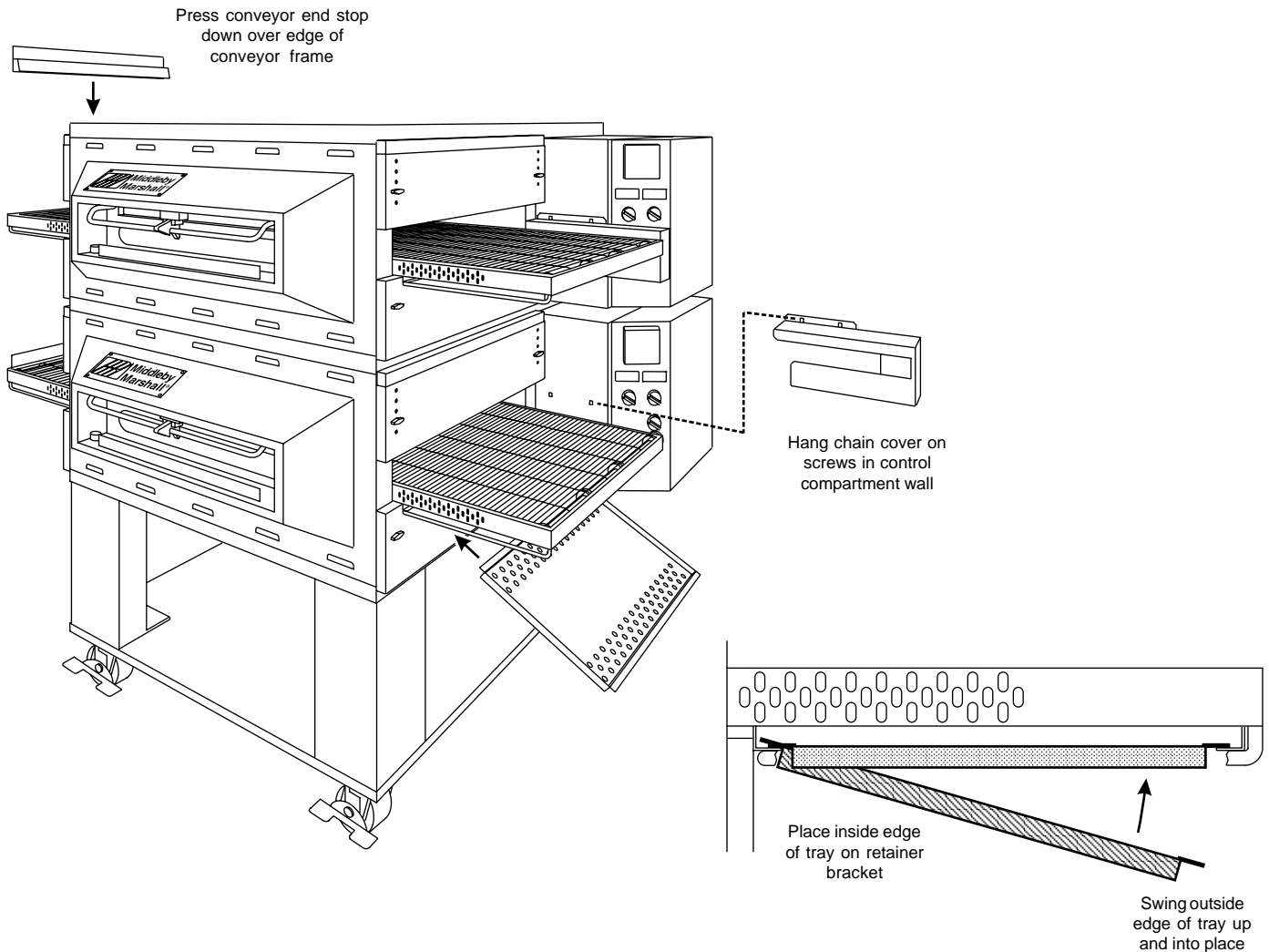

Figure 2-13 - Final assembly



IV. ELECTRICAL SUPPLY



WARNING

Authorized supplier personnel normally accomplish the connections for the ventilation system, electric supply, and gas supply, as arranged by the customer. Following these connections, the factory-authorized installer can perform the initial startup of the oven.

NOTE: The electric supply installation must satisfy the requirements of the appropriate statutory authority, such as the National Electrical Code (NEC), ANSI/NFPA70, (U.S.A.); the Canadian Electrical Code, CSA C22.2; the Australian Code, AG601; current IEC/CEE requirements (CE countries); or other applicable regulations.

NOTE: All aspects of the electrical supply connection must comply with all applicable local, national, and international code requirements.

Check the oven serial plate before making any electric supply connections. Electric supply connections must agree with data on the oven serial plate. The location of the serial plate is shown in Figure 1-1 (in Section 1, Description).

A fused disconnect switch or a main circuit breaker (customer furnished) MUST be installed in the electric supply line for each oven cavity. It is recommended that this circuit breaker/disconnect have lockout/tagout capability. For CE installations, the circuit breaker/disconnect must have a minimum of 3mm contact separation breaking all poles of the supply.

The supply conductors must comply with all applicable local, national and international codes. Supply conductors must be insulated copper wiring, #18 AWG (American Wire Gauge) or equivalent. Additional wiring information is shown on the wiring diagrams in Section 5, Electrical Wiring Diagrams and inside the machinery compartment of the oven.

The oven requires a ground connection to the oven ground screw located in the electrical junction box. (The box is shown in Figure 2-14.) The ground connection must comply with all applicable local, national, and international codes. If necessary, have the electrician supply the ground wire. *Do NOT use the wiring conduit or other piping for ground connections!*

A. Additional Information - Gas Ovens

All electric supply connections are made via the electrical junction box on the rear of the oven, shown in Figure 2-14. The power lines then connect to the oven circuits through safety switches that interrupt electric power to the oven:

- When the Control Compartment Access Panel is opened;
- When the Machinery Compartment Access Panel is opened, OR
- When the rear panel is removed.

B. Connection

Refer to the wiring diagram inside the machinery compartment, or in Section 5 of this Manual, to determine the correct connections for the electrical supply lines. Connect the supply as indicated on the wiring diagram.

If required by local, national or international codes, connect an equipotential ground wire to the lug next to the  symbol (shown in Figure 2-14). The equipotential ground connection must meet all applicable national and local code requirements.

Figure 2-14 - Utility connection locations



V. GAS SUPPLY**CAUTION****DURING PRESSURE TESTING NOTE THE FOLLOWING:**

1. The oven and its individual shutoff valve must be disconnected from the gas supply piping system during any pressure testing of that system at test pressure in excess of 1/2 psi (3.45 kPa).

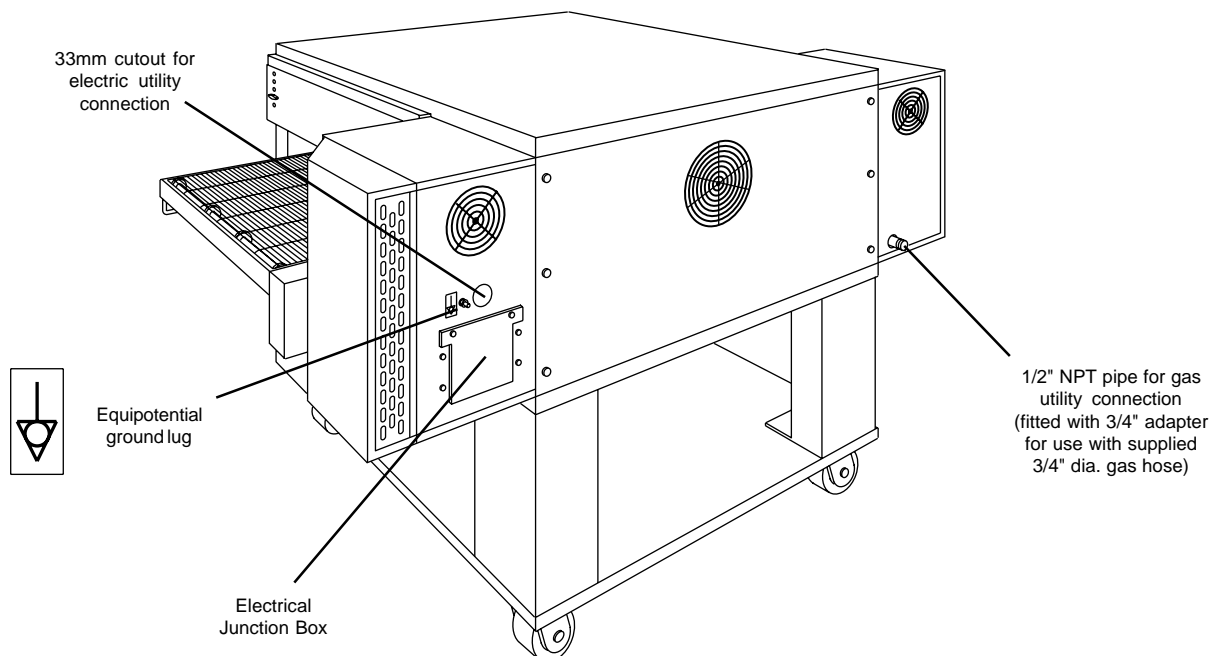
2. The oven must be isolated from the gas supply piping system by closing its individual manual shutoff valve during any pressure testing of the gas supply piping system at test pressure equal to or less than 1/2 psi (3.45 kPa).

3. If incoming pressure is over 14" W.C. (35mbar), a separate regulator **MUST** be installed in the line **BEFORE** the individual shutoff valve for the oven.

WARNING: To prevent damage to the control valve regulator during initial turn-on of gas, it is **very important** to open the manual shutoff valve **very slowly**.

After the initial gas turn-on, the manual shutoff valve must remain open except during pressure testing as outlined in the above steps or when necessary during service maintenance.

A. Gas Utility Rough-In Recommendations

The following gas system specifications are **STRONGLY RECOMMENDED**. Deviating from these recommendations may affect the baking performance of the oven.

Gas Meter - 650 cfh (307ℓ/min) meter

Gas Line

- DEDICATED LINE from the gas meter to the oven
- 2" (50.8mm) pipe for natural gas
- 1-1/2" (38.1mm) pipe for propane
- Maximum length: 200' (61m). Each 90° elbow equals 7' (2.13m) of pipe.

B. Connection

Check the oven's gas supply requirements before making the gas utility connection. Gas supply requirements are listed on the oven's serial plate and in Table 1-4. Gas Orifice and Pressure Specifications (in Section 1, Description).

Check the serial plate to determine the type of gas (Propane or Natural) to be used with the oven.

Refer to the instructions in the gas hose package (included in the Installation Kit) before connecting the gas line. One gas line connection method is shown in Figure 2-18; however, compliance with the applicable standards and regulations is mandatory.

Inlet, regulated, and pilot gas pressure readings can be taken using a digital tube manometer at the tap location shown in Figure 2-19. Figure 2-19 shows the burner assembly and Figure 2-21 shows the gas valve.

NOTE: The installation must conform with local codes or in the absence of local codes, with the National Fuel Gas Code, ANSI Z223.1-latest edition.

Certain safety code requirements exist for the installation of gas ovens; refer to the beginning of Section 2 for a list of the installation standards. In addition, because the oven is equipped with casters, the gas line connection shall be made with a connector that complies with the Standard for Connectors for Movable Gas

Appliances, ANSI Z21.69 (in U.S.A.), as well as a quick-disconnect device that complies with the Standard for Quick-Disconnect Devices for Use With Gas Fuel, ANSI Z21.41 (in U.S.A.).

C. Gas Conversion

Where permitted by local and national codes, it is possible to convert ovens from natural to propane gas, or from propane to natural gas. Use the appropriate Middleby Gas Conversion Kit for the specific oven model.

CAUTION: *The terms of the oven's warranty require all start-ups, conversions and service work to be performed by a Middleby Authorized Service Agent.*

**D. PS536 Propane Conversion**

Two items have to be changed, to change the oven to LP:

1. Replace main orifices.
2. Adjust main gas regulator per instructions below.

Disconnect the manifold union closest to the main burner, and remove the manifold assembly (four screws). Slide out the manifold assembly (leaving the ignition and sense wires connected). Replace the main orifices.

Replace the main orifices on the manifold assemblies with the LP units, and replace the manifold assembly. Reconnect the union.

E. Adjusting the Maximum Pressure Setting

1. Disconnect pressure feedback connection (if applicable).
2. Connect a suitable pressure gauge to pipe line or to outlet pressure tap of gas control concerned, to measure burner pressure (measuring point must be as near to burner as possible).
3. Make sure that the appliance is in operation and the Moduplus® coil is energized with maximum current.
4. If maximum rate pressure needs adjustment, use an 8 mm wrench to turn adjustment screw for maximum pressure setting (clockwise to increase or counter-clockwise to decrease pressure), until the desired maximum outlet pressure is obtained.

Figure 2-15 - Flexible Gas Hose Installation

Figure 2-16. Gas Burner Assembly**Figure 2-17. Burner Assembly****Figure 2-18. Gas Valve**

5. Disconnect electrical connection of the Moduplus®.
6. Check minimum pressure setting and readjust if necessary. (See Adjusting Minimum Pressure Setting for proper adjusting procedure.)
7. Reconnect pressure feedback connection (if applicable).
8. If minimum and maximum pressures are set, wire the Moduplus® in circuit.
9. Close pressure tap screw.

F. Adjusting the Minimum Pressure Setting

1. Disconnect pressure feedback connection (if applicable).
2. Connect a suitable pressure gauge to pipe line or to outlet pressure tap of gas control concerned, to measure burner pressure (measuring point must be as near to burner as possible).
3. Disconnect electrical connection of the Moduplus®.
4. Energize operator, set control in operation and wait until an outlet pressure is recorded on pressure gauge.
5. If minimum rate pressure needs adjustment, use an 8 mm wrench to turn adjustment screw for minimum pressure setting (clockwise to increase or counter-clockwise to decrease pressure), until the desired minimum outlet pressure is obtained.
6. Check if main burner lights easily and reliable at minimum pressure.
7. Reconnect pressure feedback connection (if applicable).
8. Close pressure tap screw.

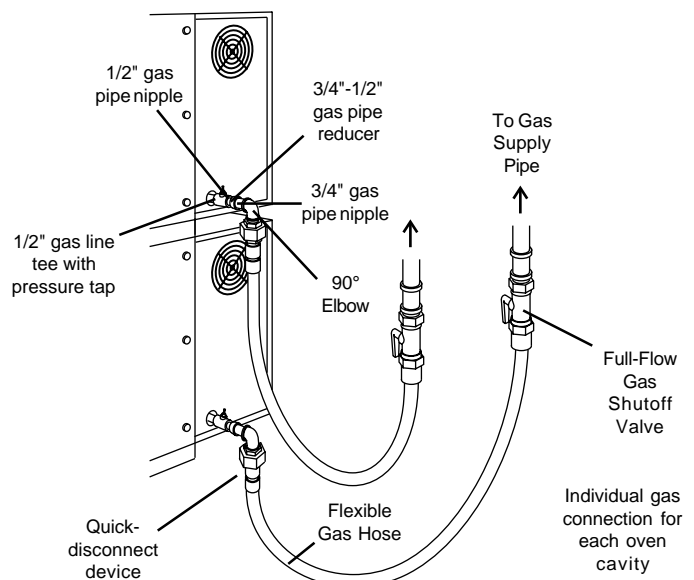
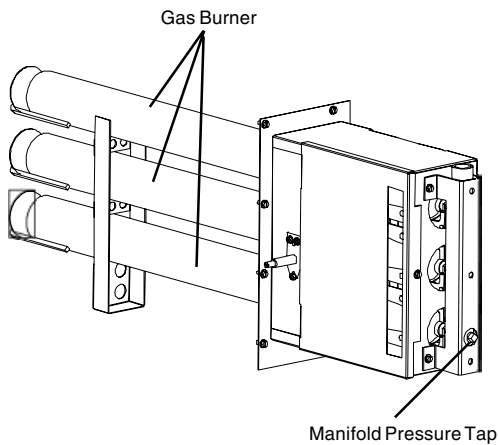
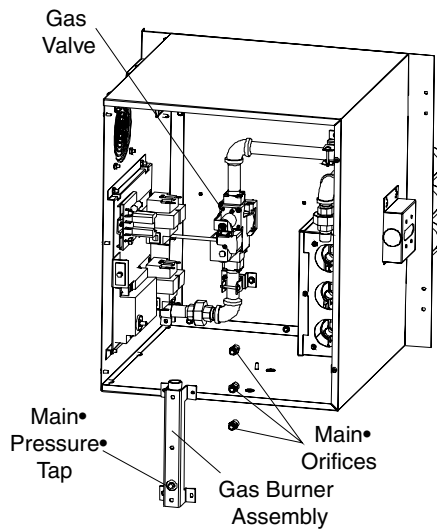
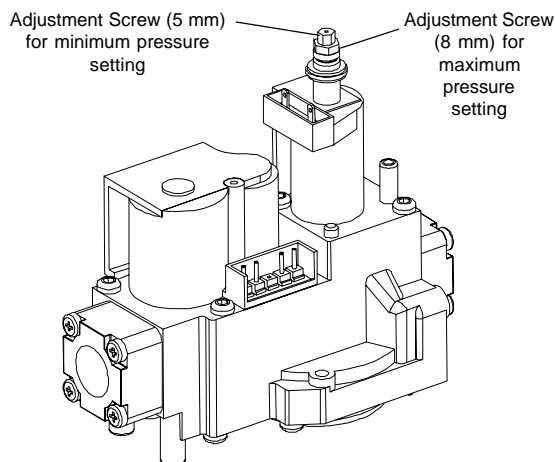
G. Checkout

After any adjustment, set appliance in operation and observe through a component cycle to ensure that burner system components function correctly.

H. Maintenance



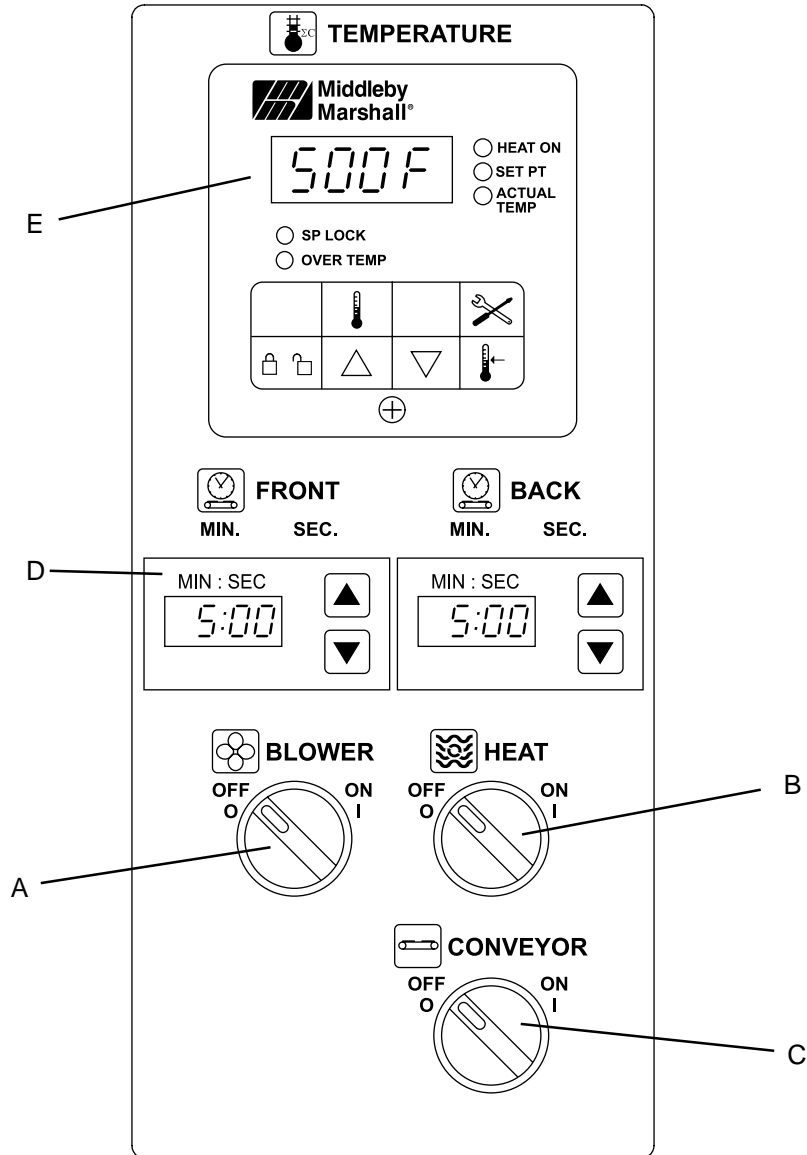

It is recommended to check yearly the minimum and the maximum setting and readjust them if necessary.

NOTES

SECTION 3- OPERATION



I. LOCATION AND DESCRIPTION OF CONTROLS

- A.  **"BLOWER" Switch:** Turns the blowers and cooling fans on and off. The HEAT Switch has no effect unless the BLOWER Switch is in the "ON" position.
- B.  **"HEAT" Switch:** Allows the burner to activate. Activation is determined by the settings on the Digital Temperature Controller.
- C.  **"CONVEYOR" Switch:** Turns the conveyor drive motor on and off.
- D.  **Conveyor Speed Controller:** Adjusts and displays the bake time. Single-belt ovens have one controller. Split belt ovens have one controller for each conveyor belt, labeled "FRONT" and "BACK."
- E.  **Digital Temperature Controller:** Continuously monitors the oven temperature. Settings on the Digital Temperature Controller control the activation of the burner. Keypad controls allow the operator to select the cooking temperature and monitor oven operation.

NOT SHOWN:

- F. **Machinery and Control Compartment Safety Switches:** Disconnect electrical power to the controls and blowers when EITHER the machinery compartment door OR the control compartment door is opened. The doors should only be opened by authorized service personnel.

II. NORMAL OPERATION - STEP-BY-STEP

A. DAILY STARTUPPROCEDURE

1. Check that the circuit breaker/fused disconnect is in the on position. Check that the window is closed.

2. Turn the "BLOWER" (🌀) switch to the "ON" ("I") position.

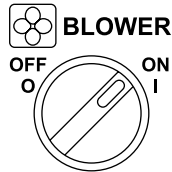

3. Turn the "CONVEYOR" (⇐⇒) switch to the "ON" ("I") position.

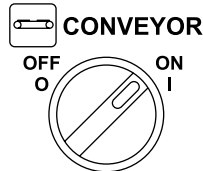

4. If necessary, adjust the conveyor speed setting by pressing the ▲ or ▼ pushbuttons on the conveyor speed controller to change the displayed bake time.

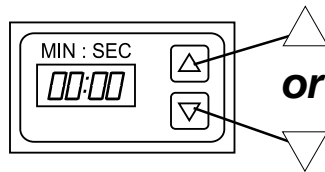

5. Adjust the temperature controller to a desired set temperature, if necessary.

- Press the Set Point and Unlock keys at the same time. Wait for the "SET PT" light to turn on.

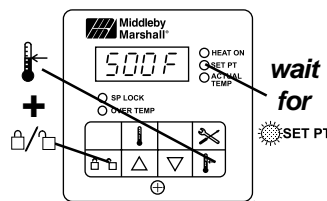

- Press the Up Arrow and Down Arrow Keys as necessary to adjust the set-point.

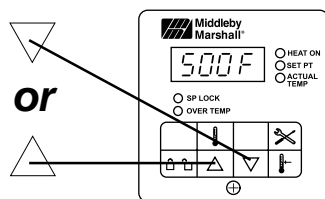

6. Turn the "HEAT" (🔥) switch to the "ON" ("I") position, and wait for the "HEAT ON" light to turn on.

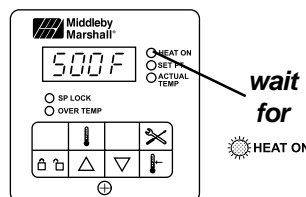

7. Wait for the oven to heat to the setpoint temperature. Higher setpoint temperatures will require a longer wait. The oven can reach a temperature of 500°F (232°C) in approximately 5 minutes.

8. (Optional) Press the Temperature (🌡️) key to show the Actual Temperature in the display, and wait for the "ACTUAL TEMP" light to turn on. This allows you to monitor the oven temperature as it rises to the setpoint.

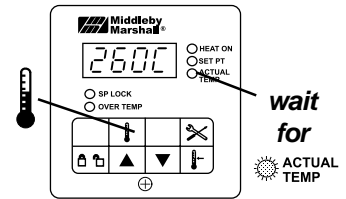

9. Allow the oven to preheat for 10 minutes after it has reached the set point temperature.

B. DAILY SHUTDOWNPROCEDURE

1. Turn the "HEAT" (🔥) and "BLOWER" (🌀) switches to the "OFF" ("O") position. Note that the blowers will remain in operation until the oven has cooled to below 200°F (93°C).

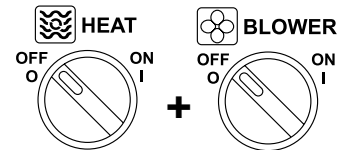

2. Make certain that there are no products left on the conveyor inside the oven. Turn the "CONVEYOR" (⇐⇒) switch to the "OFF" ("O") position.

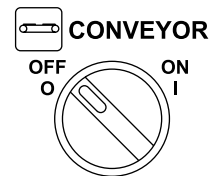

3. Open the window to allow the oven to cool faster.

4. After the oven has cooled and the blowers have turned off, switch the circuit breaker/fused disconnect to the off position.

IMPORTANT

On gas ovens, if the "HEAT ON" light will not illuminate, OR if the oven does not heat, the gas burner may not have lit. Turn the "HEAT" (🔥), "BLOWER" (🌀), and "CONVEYOR" (⇐⇒) switches to the "OFF" ("O") position. Wait for AT LEAST FIVE MINUTES before restarting the oven. Then, repeat the Daily Startup procedure.

CAUTION

In case of power failure, turn all switches to the "OFF" ("O") position, open the oven window, and remove the product. After the power has been restored, perform the normal startup procedure. IF THE OVEN WAS SWITCHED OFF FOR LESS THAN 5 MINUTES, WAIT FOR AT LEAST FIVE MINUTES BEFORE RESTARTING THE OVEN.

The burner will not operate and gas will not flow through the burner without electric power. No attempt should be made to operate the oven during a power failure.

III. QUICK REFERENCE: DIGITAL TEMPERATURE CONTROLLER

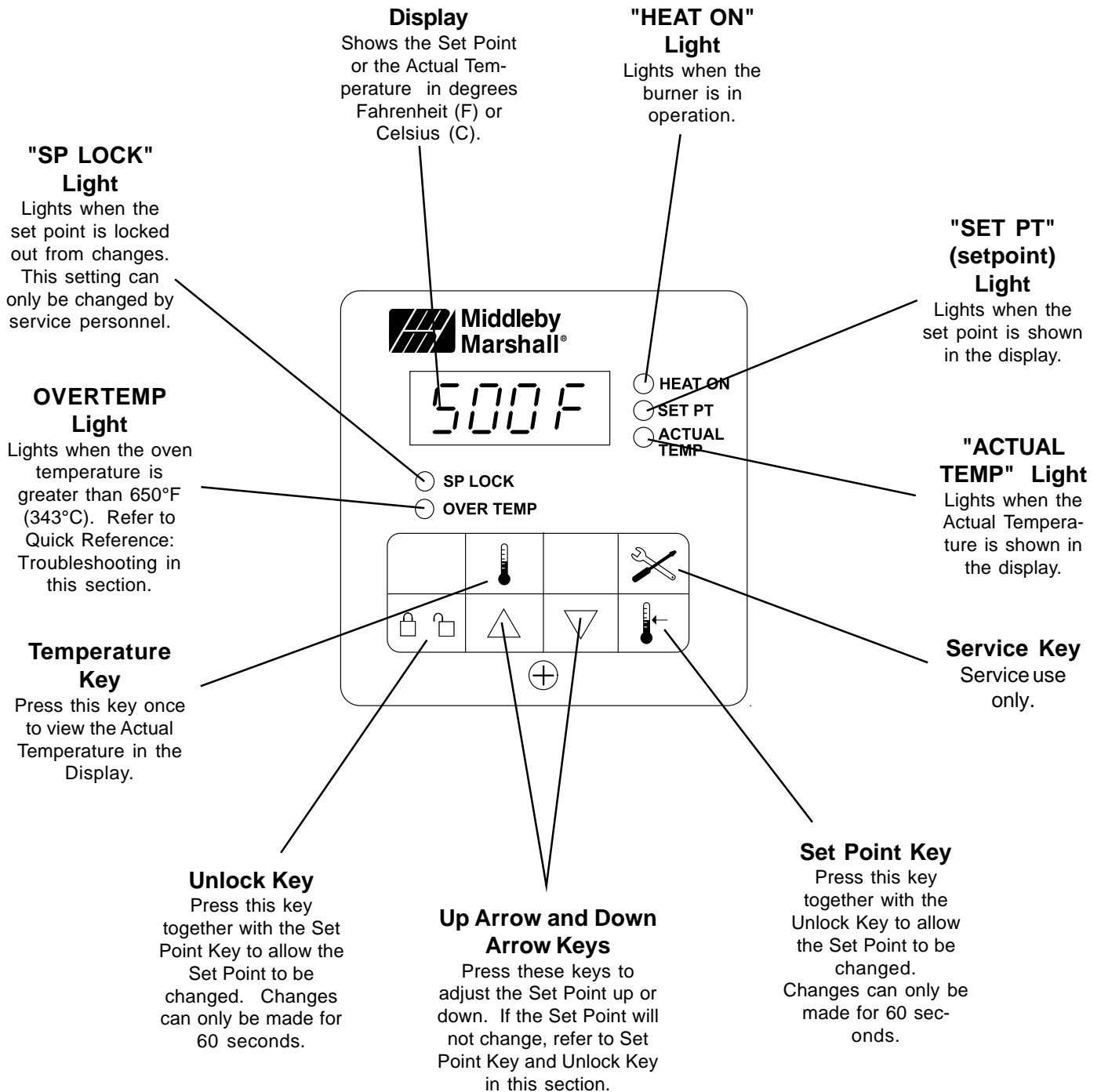

SECTION 4 - MAINTENANCE

WARNING

Before ANY cleaning or servicing of the oven, perform the following procedure:

1. Switch off the oven and allow it to cool. Do NOT service the oven while it is warm.
2. Turn the full-flow gas safety valve to the off position.
3. Turn off the electric supply circuit breaker(s) and disconnect the electric supply to the oven.
4. If it is necessary to move a gas oven for cleaning or servicing, disconnect the gas supply before moving the oven.

When all cleaning and servicing is complete:

1. If the oven was moved for servicing, return the oven to its original location.
2. Reconnect the gas supply.
3. Reconnect the electrical supply.
4. Turn on the full-flow gas safety valve. Test the gas line connections for leaks using approved leak test substances or thick soap suds.
5. Turn on the electric supply circuit breaker(s).
6. Perform the normal startup procedure.

WARNING

Possibility of injury from moving parts and electrical shock exists in this oven. Switch off and lockout/tagout the electric supply BEFORE beginning to disassemble, clean, or service any oven. Never disassemble or clean an oven with the BLOWER (⊗) switch or any other circuit of the oven switched on.

CAUTION

NEVER use a water hose or pressurized steam-cleaning equipment when cleaning this oven. To avoid saturating the oven insulation, DO NOT use excessive amounts of water. DO NOT use a caustic oven cleaner, which can damage the bake chamber surfaces.

NOTE

ANY replacement parts that require access to the interior of the oven may ONLY be replaced by a Middleby Marshall Authorized Service Agent. It is also strongly recommended that the 3-Month Maintenance and 6-Month Maintenance procedures in this section be performed ONLY by a Middleby Marshall Authorized Service Agent.

I. MAINTENANCE - DAILY

- A. Check that the oven is cool and the power is disconnected, as described in the warning at the beginning of this Section.
- B. Clean ALL of the cooling fan grills and vent openings with a stiff nylon brush. Refer to Figure 4-1 for the locations of the grills and vents.
- C. Clean the outside of the oven with a soft cloth and mild detergent.
- D. Check that ALL cooling fans are operating properly.

CAUTION

If a cooling fan is not operating correctly, it must be replaced IMMEDIATELY. Operating the oven without adequate cooling can seriously damage the oven's internal components.

- E. Clean the conveyor belts with a stiff nylon brush. This is more easily accomplished by allowing the conveyor to run while you stand at the exit end of the conveyor. Then, brush the crumbs off the conveyor as it moves.
- F. Remove and clean the crumb trays. If necessary, refer to Figure 2-13 (in Section 2, Installation) when replacing the crumb trays into the oven.
- G. Clean the window in place.

Figure 4-1 -Cooling Vents and Grills

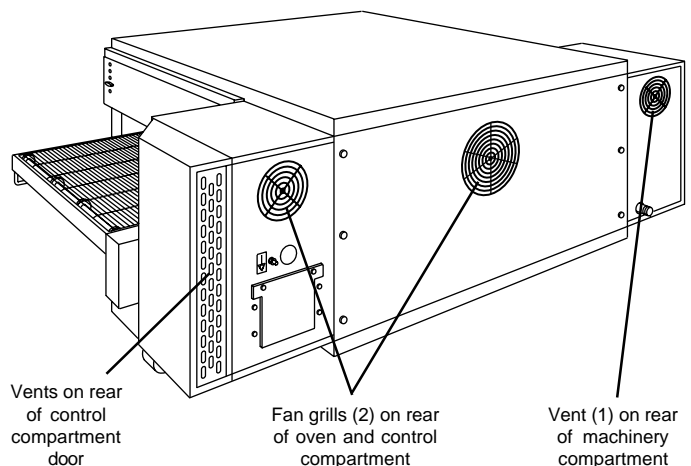
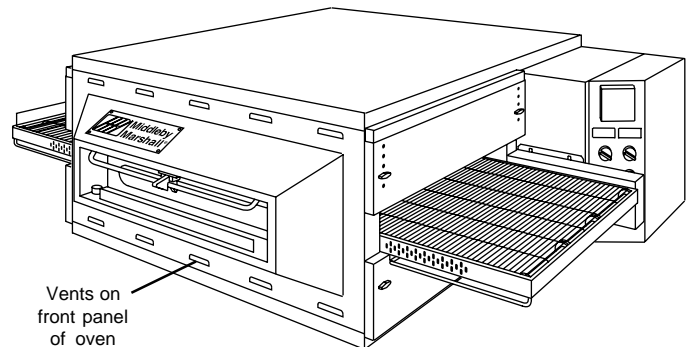

II. MAINTENANCE - MONTHLY

- A. Check that the oven is cool and the power is disconnected, as described in the warning at the beginning of this Section.
- B. Refer to Part D, Conveyor Installation, in the Installation section of this Manual. Then, remove the following components from the oven:
- Conveyor end stop
 - Crumb trays
 - Chain cover
 - Drive chain
 - End plugs
 - Conveyor assembly
- C. Slide the air fingers and blank plates out of the oven, as shown in Figure 4-2. AS EACH FINGER OR PLATE IS REMOVED, WRITE A "LOCATION CODE" ON IT WITH A MARKER to make sure that it can be reinstalled correctly.
- Example of markings:
- | | | | | |
|--------------|-----------|-----------|-----------|-----------|
| (Top Row) | T1 | T2 | T3 | T4 |
| (Bottom Row) | B1 | B2 | B3 | B4 |
- D. Disassemble the air fingers. See Figure 4-3. AS EACH FINGER IS DISASSEMBLED, WRITE THE "LOCATION CODE" FOR THE FINGER ON ALL THREE OF ITS PIECES. This will help you in correctly reassembling the air fingers.

CAUTION

Incorrect reassembly of the air fingers will change the baking properties of the oven.

- E. Clean the air finger components and the interior of the baking chamber using a vacuum cleaner and a damp cloth. Refer to the boxed warnings at the beginning of this Section for cleaning precautions.
- F. Reassemble the air fingers. Then, replace them in the oven, using the "location code" as a guide.
- G. Install the end plugs on the oven. Then, reinstall the conveyor.
- I. Reattach the drive chain. Replace the chain cover.
- J. Check the tension of the conveyor belt as shown in Figure 2-11 (in Section 2, Installation). The belt should lift about 1" (25mm). If necessary, adjust the belt tension using the procedure in Part D (Conveyor Installation) in the Installation section of this Manual.
- K. Replace all components onto the oven.

III. MAINTENANCE - EVERY 3 MONTHS

- A. Check that the oven is cool and the power is disconnected, as described in the warning at the beginning of this Section.
- B. Open the machinery compartment access panel. Vacuum the inside of the compartment using a shop vacuum.
- C. Tighten all electrical control terminal screws.
- D. **Split Belt Disassembly and Cleaning**
1. Refer to Part D, Conveyor Installation, in the Installation section of this Manual. Then, remove the following components from the oven:
 - Conveyor end stop
 - Crumb trays
 - Chain cover
 - Drive chains
 - End plugs
 - Conveyor assembly

Figure 4-2 - Removing Air Fingers and Plates

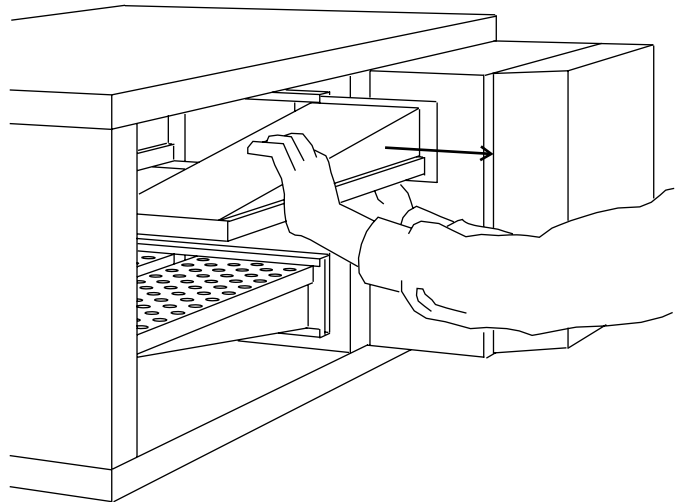
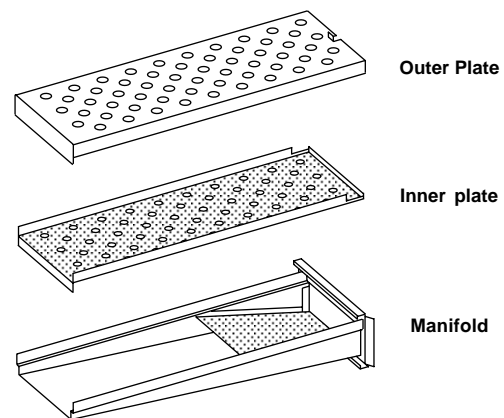

Figure 4-3 - Disassembling the Air Fingers



SECTION 4 - MAINTENANCE

2. Remove the master links from each conveyor belt. Then, roll the belts up along the length of the conveyor to remove them from the frame.
3. Remove the two conveyor adjustment screws from the idler end of the conveyor frame, as shown in Figure 4-4.
4. Remove the idler shaft assembly from the conveyor.
5. Pull apart the two sections of the idler shaft.
6. Clean the shafts thoroughly using a rag. Then, lubricate both the extended shaft and the interior of the hollow shaft using a light food-grade lubricant. DO NOT lubricate the shafts using WD40 or a similar product. This can cause the shafts to wear rapidly.
7. Before reassembling the shafts into the conveyor frame, check that they are oriented properly.
8. Reassemble the idler shaft into the conveyor. Make sure that the bronze washer is in place between the two sections of the shaft. See Figure 4-4.
9. Replace the conveyor adjustment screws as shown in Figure 4-4. To allow the conveyor belt to be reinstalled later, do not tighten the screws at this time.
10. Loosen the set screw on both of the conveyor drive sprockets. Then, remove the sprockets from the shaft.
11. Check the conveyor configuration as follows:
 - High-speed conveyors are equipped with large flange bearings at both ends of the shaft, as shown in Figure 4-5. For these conveyors, remove the two screws that hold each bearing to the conveyor frame. With the screws removed, lift the end of the shaft at the front of the oven, and pull the entire assembly free of the conveyor frame.
 - Standard conveyors are equipped with bronze bushings mounted on spacers at both ends of the shaft, as shown in Figure 4-5. For these conveyors, remove the two screws that hold the bracket to the conveyor frame. With the screws removed, lift the end of the shaft at the front of the oven, and pull the entire assembly free of the conveyor frame. The brackets will be removed along with the drive shaft assembly.

Figure 4-4 - Disassembling the idler shaft

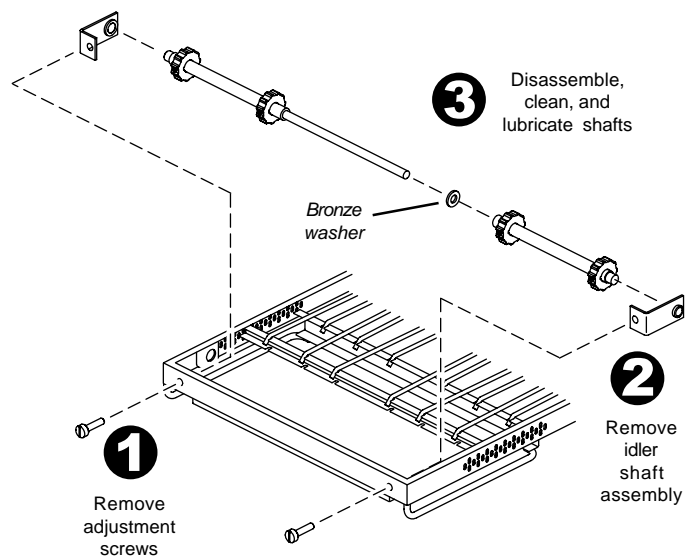

Figure 4-5 - Drive shaft configurations

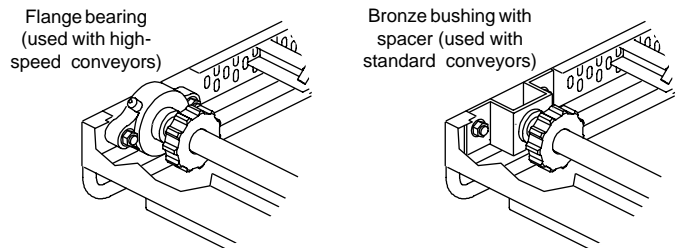
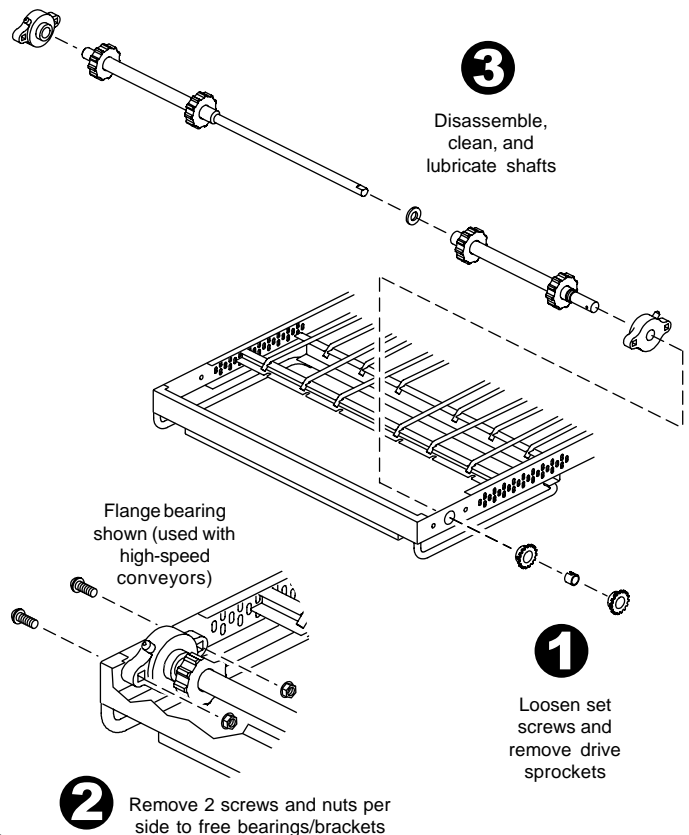

Figure 4-6 - Disassembling the drive shaft



12. Disassemble and lubricate the two sections of the drive shaft as described for the idler shaft, above.
13. Before reassembling the shafts into the conveyor frame, check that they are oriented properly.
14. Reassemble the drive shaft into the conveyor. Make sure that the bronze washer is in place between the two sections of the shaft. See Figure 4-6.
15. Replace the drive sprockets. Reassemble the belts and master links onto the conveyor.
16. Reinstall the end plugs and conveyor onto the oven.
17. Reattach the drive chains. Replace the chain cover.
18. Check the tension of the conveyor belt as shown in Figure 2-11 (in Section 2, Installation). The belt should lift about 1" (25mm). If necessary, adjust the belt tension by turning the conveyor adjustment screws.
19. Replace all components onto the oven.

E. Blower Belt

1. Remove the six screws shown in Figure 4-7. Then, remove the rear panel from the oven.
2. Check the blower belt for the proper 1/4" (6mm) deflection at the center, and for cracking or excessive wear. See Figure 4-7. Overtightening the belt will cause premature bearing failure and possible vibrations. A loose belt may also cause vibrations.
3. If necessary, adjust the tension of the belt by loosening the four motor mounting bolts. Reposition the motor as necessary until the correct 1/4" (6mm) deflection is reached, then tighten the bolts.

F. Lubricating the Blower Fan Bearings

1. Use a grease gun to lubricate the main blower fan shaft bearings, as shown in Figure 4-7.

When lubricating the bearings:

- Use a high-quality NLGI #2, lithium soap grease with petroleum oil, such as Middleby P/N 17110-0015.
 - Add the grease slowly until a small bead of grease is present at the seals. AVOID OVERGREASING. Excessive greasing may cause harm to the bearing.
2. Manually turn the blower shaft by pulling on the belt to purge the grease. Wipe off any excess grease.
 3. Replace the rear panel onto the oven.

IV. MAINTENANCE - EVERY 6 MONTHS

- A. Check that the oven is cool and the power is disconnected, as described in the warning at the beginning of this Section.
- B. Check for excessive wear on the conveyor drive motor brushes. The brushes should be replaced if they have worn to less than 1/4" (6mm) in length. Be sure to replace the brushes in exactly the same position.
- C. For gas ovens, inspect and clean the burner nozzle and the spark electrode assembly.
- D. Check the conveyor drive shaft bushings and spacers. Replace the components if they are worn.

Figure 4-7 - Rear panel access

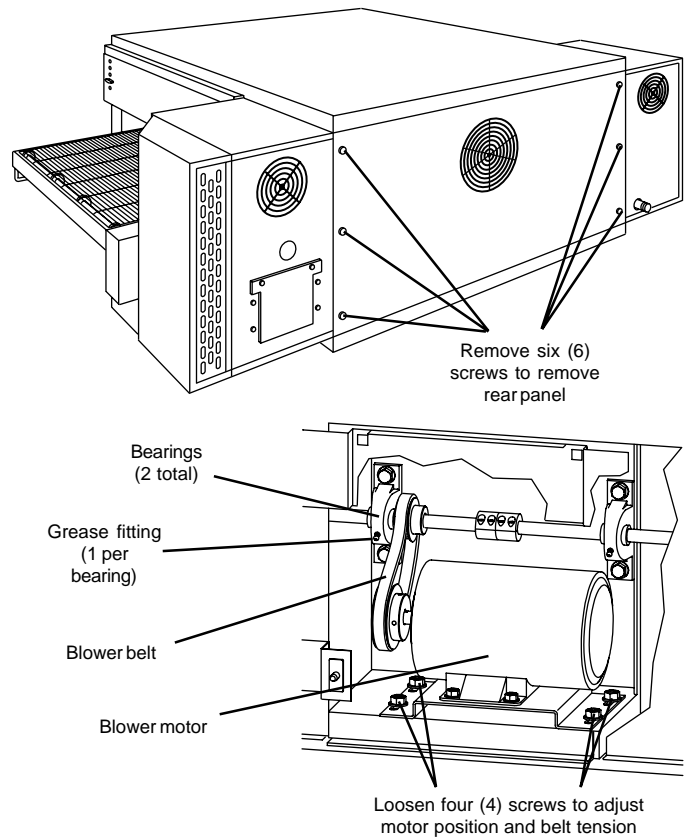

SECTION 5 - PARTS LIST

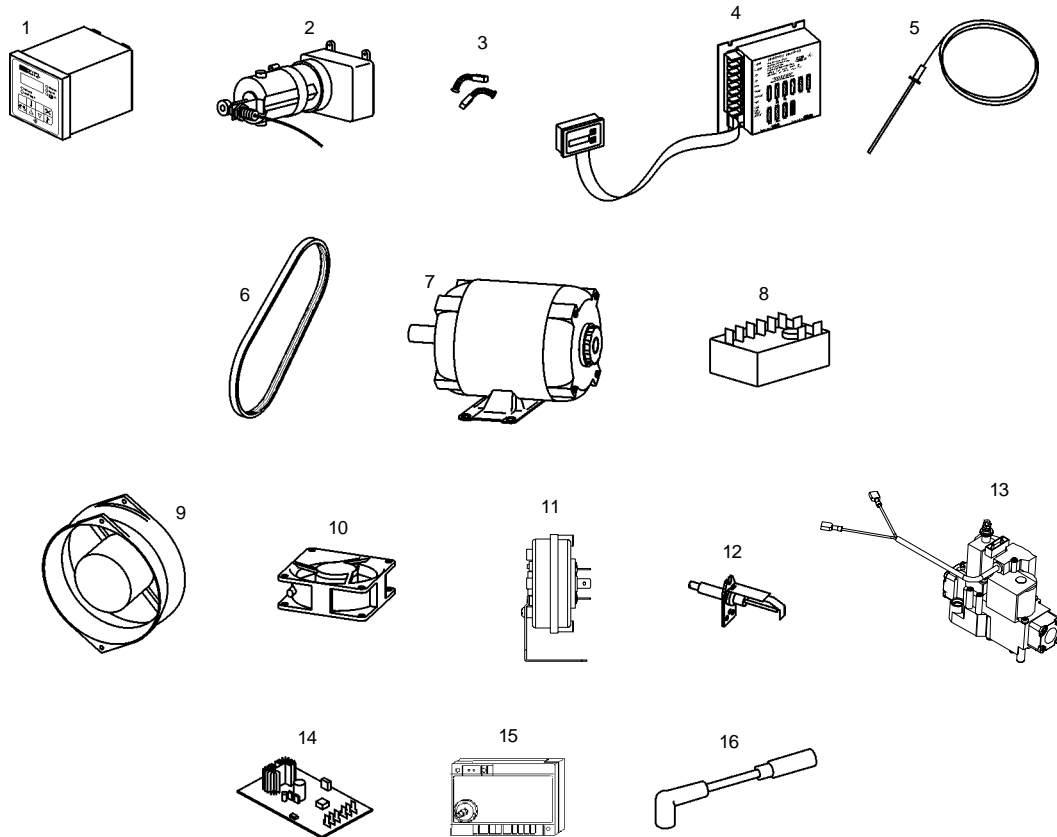

I. KEY SPARE PARTS KIT

| ITEM | QTY. | P/N | DESCRIPTION |
|------|------|-------|--|
| 1 | 1 | 47321 | DIGITAL TEMPERATURE CONTROLLER |
| 2 | 1 | 51067 | CONVEYOR DRIVE MOTOR W/PICKUP ASSY. |
| 3 | 2 | 30153 | DRIVE MOTOR BRUSHES |
| 4 | 1 | 60542 | KIT, CONVEYOR SPEED CONTROLER |
| 5 | 1 | 33984 | KIT, THERMOCOUPLE 6" |
| 6 | 1 | 50517 | BELT, BLOWER |
| 7 | 1 | 44687 | MOTOR, BLOWER, 208/230V, 1/2HP |
| 8 | 1 | 33983 | HIGH LIMIT CONTROL MODULE, 240V |
| 9 | 1 | 36451 | COOLING FAN (BACKWALL) |
| 10 | 1 | 97525 | COOLING FAN (CONTROL COMPARTMENT) |
| 11 | 1 | 60836 | AIR SWITCH |
| 12 | 1 | 48455 | IGNITOR |
| 13 | 1 | 60679 | COMBINATION GAS CONTROL VALVE (SAFETY REGULATOR) |
| 14 | 1 | 60671 | AMPLIFIER BOARD |
| 15 | 1 | 50239 | IGNITION MODULE |
| 16 | 1 | 50240 | IGNITION CABLE, 25" |

NOTES

NOTES

WARNING

Improper installation, adjustment, alteration, service or maintenance can cause property damage, injury or death. Read the installation, operating and maintenance instructions thoroughly before installing or servicing this equipment.

NOTICE

During the warranty period, ALL parts replacement and servicing should be performed by your Middleby Marshall Authorized Service Agent. Service that is performed by parties other than your Middleby Marshall Authorized Service Agent may void your warranty.

NOTICE

Using any parts other than genuine Middleby Marshall factory manufactured parts relieves the manufacturer of all warranty and liability.

NOTICE

Middleby Marshall reserves the right to change specifications at any time.



Commercial Food Equipment Service Association

Middleby is proud to support the Commercial Food Equipment Service Association (CFESA). We recognize and applaud CFESA's ongoing efforts to improve the quality of technical service in the industry.

Middleby Cooking Systems Group • 1400 Toastmaster Drive • Elgin, IL 60120 • USA • (847)741-3300 • FAX (847)741-4406

24-Hour Service Hotline: 1-(800)-238-8444

www.middleby.com

