

Middleby Cooking Systems Group



1400 Toastmaster Drive • Elgin, IL 60120-9272 U. S. A. • Telephone: (847)741-3300 • Service and Parts Fax: (847)741-4406



SUBJECT

Return of TP44 and TP120 Support and Elevator Assemblies with broken Roller Cam Pins.

GENERAL

Toastmaster Service has become aware of a potential weakness in the Roller Cam Pin located on the Support and Elevator Assembly (P/N 760-6059) for the TP44 and TP120 Slot Toasters. The Assembly, Pin, and Roller are shown in the drawing below.

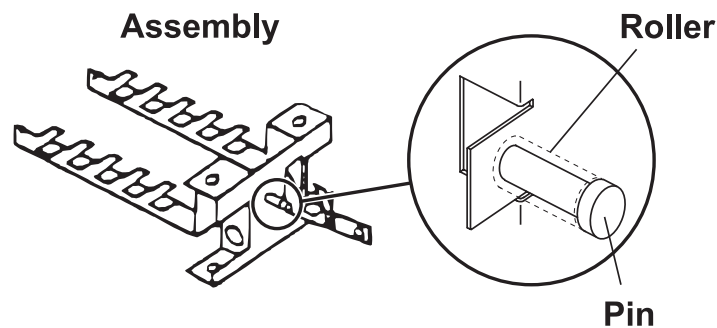

To help in diagnosing and correcting this weakness, Toastmaster Service requests that all Support and Elevator Assemblies from these toasters that are found with broken Roller Cam Pins during servicing be returned to Toastmaster Service.

APPLICATION

When replacing a Support and Elevator Assembly (P/N 760-6059) on an affected Pop-Up Toaster *that is still covered under its service warranty*, check the status of the Roller Cam Pin. If the pin is broken or loose, please return the entire Assembly to Toastmaster Service. If the pin is unbroken and securely attached to the Assembly, discard the Assembly as per the normal replacement procedure.

COMPATIBILITY

This Bulletin applies to the Support and Elevator Assemblies (P/N 760-6059) of Toastmaster Model TP-44 and TP-120 Pop-Up Toasters that are still covered under their service warranty.

FEATURES - n/a

AVAILABILITY - n/a

DISPOSITION OF INVENTORY

Existing stock of P/N 760-6059 should be used normally.